

# MAXIM

## Very Fast Buffer Amplifiers

LH0063/BB3553

### General Description

The BB3553 and LH0063 are high speed, FET input, voltage follower/buffers designed to provide high current drive at frequencies from DC to 300MHz. Both devices are similar in their slew rate; up to 6000 volts per microsecond with light loads and 2000 volts per microsecond with a 50 ohm load. The LH0063 is not internally current limited, giving added versatility and higher transient drive capability.

### Applications

- High Speed Line Drivers
- Video Drivers/Impedance Transformation
- Nuclear Instrumentation Amplifiers
- Operational Amplifier Isolation
- High Speed A to D Input Buffers
- Video Cross Point Switches

### Features

- ◆ Pin for Pin 2nd Source
- ◆ 6000V/ $\mu$ Sec Slew Rate
- ◆ DC to 300MHz Bandwidth
- ◆  $\pm 10V$  Output Drive Into 50 $\Omega$
- ◆ 2ns Rise and Fall Times
- ◆ Wide Range Single or Dual Supply Operation
- ◆ 10G $\Omega$  Input Resistance

### Ordering Information

PART	TEMP. RANGE	PACKAGE
LH0063CK	-25°C to +85°C	8 Lead TO-3
LH0063K	-55°C to +125°C	8 Lead TO-3
BB3553AM	-25°C to +85°C	8 Lead TO-3

### Typical Operating Circuit

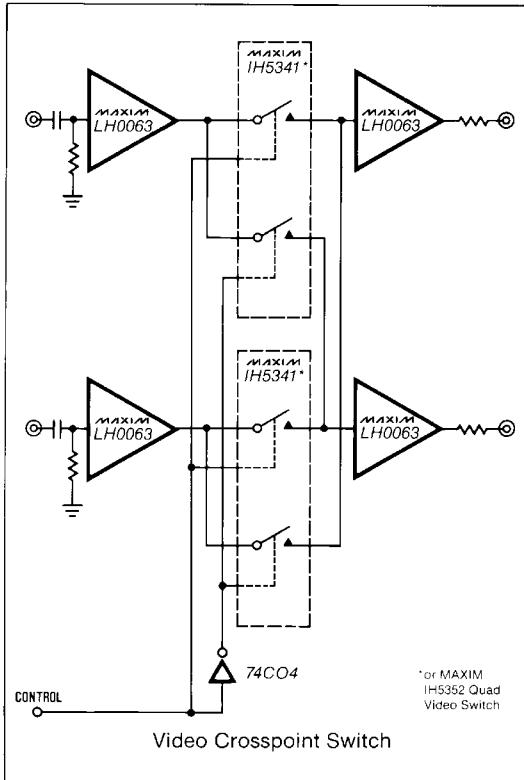

### Pin Configurations

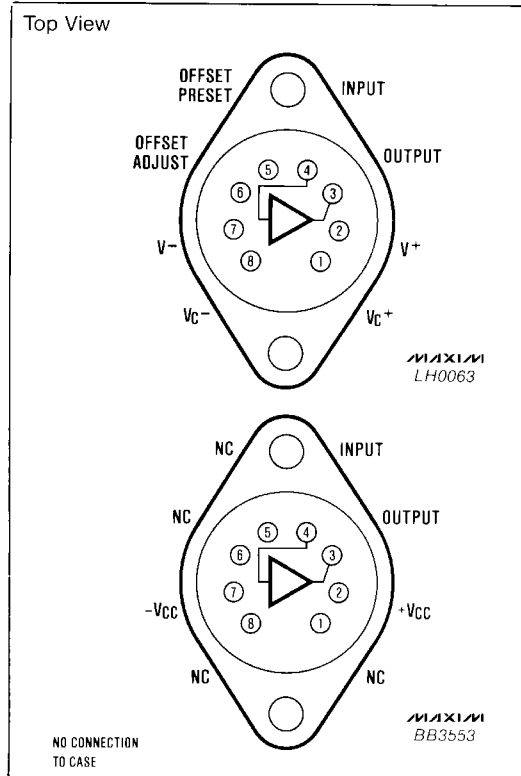

## Very Fast Buffer Amplifiers

### ABSOLUTE MAXIMUM RATINGS

Supply Voltage (V <sup>+</sup> - V <sup>-</sup> )	40V	Peak Output Current	±500mA
Maximum Power Dissipation (See Curves)	5W	Operating Temperature Range	
Maximum Junction Temperature	175°C	LH0063	-55°C to +125°C
Input Voltage	V <sup>+</sup> to V <sup>-</sup>	LH0063C and BB3553AM	-25°C to +85°C
Continuous Output Current	±250mA	Storage Temperature Range	-65°C to +150°C
		Lead Temperature (Soldering, 10 sec.)	+300°C

Stresses above those listed under "Absolute Maximum Ratings" may cause permanent damage to the device. These are stress ratings only and functional operation of the device at these or any other conditions above those indicated in the operational sections of the specifications is not implied. Exposure to absolute maximum rating conditions for extended periods may affect device reliability.

### DC ELECTRICAL CHARACTERISTICS

(V<sub>S</sub> = ±15V, T<sub>MIN</sub> ≤ T<sub>A</sub> ≤ T<sub>MAX</sub> unless otherwise specified) (Note 1)

PARAMETER	CONDITIONS	LH0063			LH0063C			BB3553AM			UNITS
		MIN	TYP	MAX	MIN	TYP	MAX	MIN	TYP	MAX	
Output Offset Voltage	R <sub>S</sub> ≤ 100kΩ, T <sub>J</sub> = 25°C R <sub>L</sub> = 100Ω		10	25	10	50			50		mV mV
Average Temperature Coefficient of Output Offset Voltage	R <sub>S</sub> ≤ 100kΩ (Note 3)		300		300			300			μV/°C
Input Bias Current	T <sub>J</sub> = 25°C (Note 2) V <sub>IN</sub> = ±1V		0.5	30	0.5	30		0.5	30		nA
Voltage Gain	V <sub>IN</sub> = ±10V, R <sub>S</sub> ≤ 100kΩ R <sub>L</sub> = 1kΩ	0.94	0.96	1.00	0.94	0.96	1.00				V/V
Voltage Gain	V <sub>IN</sub> = ±10V, R <sub>S</sub> ≤ 100kΩ R <sub>L</sub> = 50Ω, T <sub>J</sub> = 25°C	0.92	0.93	0.98	0.91	0.93	0.98	0.92	0.93	0.98	V/V
Input Capacitance	T <sub>A</sub> = 25°C (Note 3)		8.0		8.0			8.0			pF
Input Resistance	V <sub>IN</sub> = ±1V, T <sub>A</sub> = 25°C	10 <sup>8</sup>	10 <sup>10</sup>		10 <sup>8</sup>	10 <sup>10</sup>		10 <sup>8</sup>	10 <sup>10</sup>		Ω
Output Impedance	V <sub>OUT</sub> = ±10V, R <sub>S</sub> ≤ 100kΩ, R <sub>L</sub> = 50Ω		1.0	4.0	1.0	4.0		1.0	4.0		Ω
Output Current Swing	V <sub>IN</sub> = ±10V, R <sub>S</sub> ≤ 100kΩ	0.2	0.6		0.2	0.6		0.2	0.4		A
Output Voltage Swing	R <sub>L</sub> = 50Ω	10	13		10	13		10			V
Output Voltage Swing	V <sub>S</sub> = ±5V, R <sub>L</sub> = 50Ω, T <sub>J</sub> = 25°C	5.0	7.0		5.0	7.0					V
Supply Current	T <sub>J</sub> = 25°C, R <sub>L</sub> = ∞, V <sub>S</sub> = ±15V (Note 4)		35	65		35	65		50	80	mA
Supply Current	V <sub>S</sub> = ±5V (Note 4)		50		50						mA
Power Consumption	T <sub>J</sub> = 25°C, R <sub>L</sub> = ∞, V <sub>S</sub> = ±15V (Note 4)		1.05	1.95		1.05	1.95		1.5	2.4	W
Power Consumption	V <sub>S</sub> = ±5V (Note 4)		500		500						mW
External Offset Resistance	V <sub>OS</sub> = 0mV, T <sub>A</sub> = 25°C (Note 5)	0	300	1000	0	300	1000				Ω

**Note 1:** All devices are 100% tested at 25°C only. Specifications at temperature extremes are sample tested to 10% LTPD. These limits are not used to calculate outgoing quality level.

**Note 2:** Specification is at 25°C junction temperature due to requirements of high speed automatic testing. Actual values at operating temperature will exceed the value at T<sub>J</sub> = 25°C. When supply voltages are ±15V, no-load operating junction temperature without a heat sink may rise 20-30°C above ambient, and more under heavy load conditions. Accordingly, V<sub>OS</sub> may change one to several mV, and I<sub>B</sub> will change significantly during warm-up. Refer to I<sub>B</sub> vs. temperature graph for expected values.

**Note 3:** QA sample tested only.

**Note 4:** Guaranteed through correlated automatic pulse testing at T<sub>J</sub> = 25°C.

**Note 5:** Offset adjust resistor for LH0063 connects between device pin 6 and V<sup>-</sup>.

# Very Fast Buffer Amplifiers

LH0063/BB3553

## AC ELECTRICAL CHARACTERISTICS

( $V_S = \pm 15V$ ,  $T_A = 25^\circ C$ ,  $R_S = 50\Omega$ ,  $R_L = 50\Omega$  (Note 6))

PARAMETER	CONDITIONS	LH0063			LH0063C			BB3553AM			UNITS
		MIN	TYP	MAX	MIN	TYP	MAX	MIN	TYP	MAX	
Slew rate	$R_L = 1k\Omega$ , $V_{IN} = \pm 10V$	6000			6000			6000			$V/\mu S$
Slew rate	$R_L = 50\Omega$ , $V_{IN} = \pm 10V$ , $T_J = 25^\circ C$	2000	2400		2000	2400		2000	2400		$V/\mu S$
Bandwidth	$V_{IN} = 1.0V_{rms}$	300			300			300			MHz
Bandwidth	Full Power, $V_{IN} = 10V_{p-p}$	32			32			32			MHz

**Note 6:** Not 100% production tested; verified by sample testing only. Limits are not used to calculate outgoing quality level.

## Typical Operating Characteristics

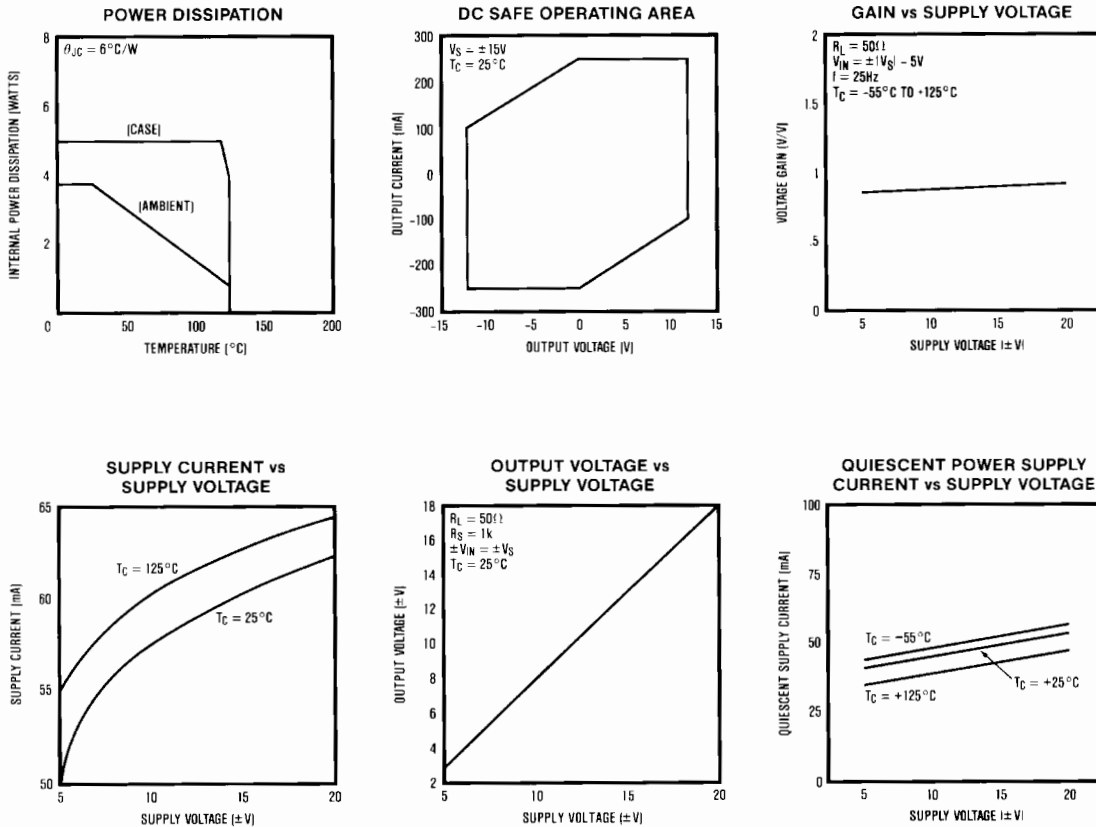

# Very Fast Buffer Amplifiers

## Typical Operating Characteristics

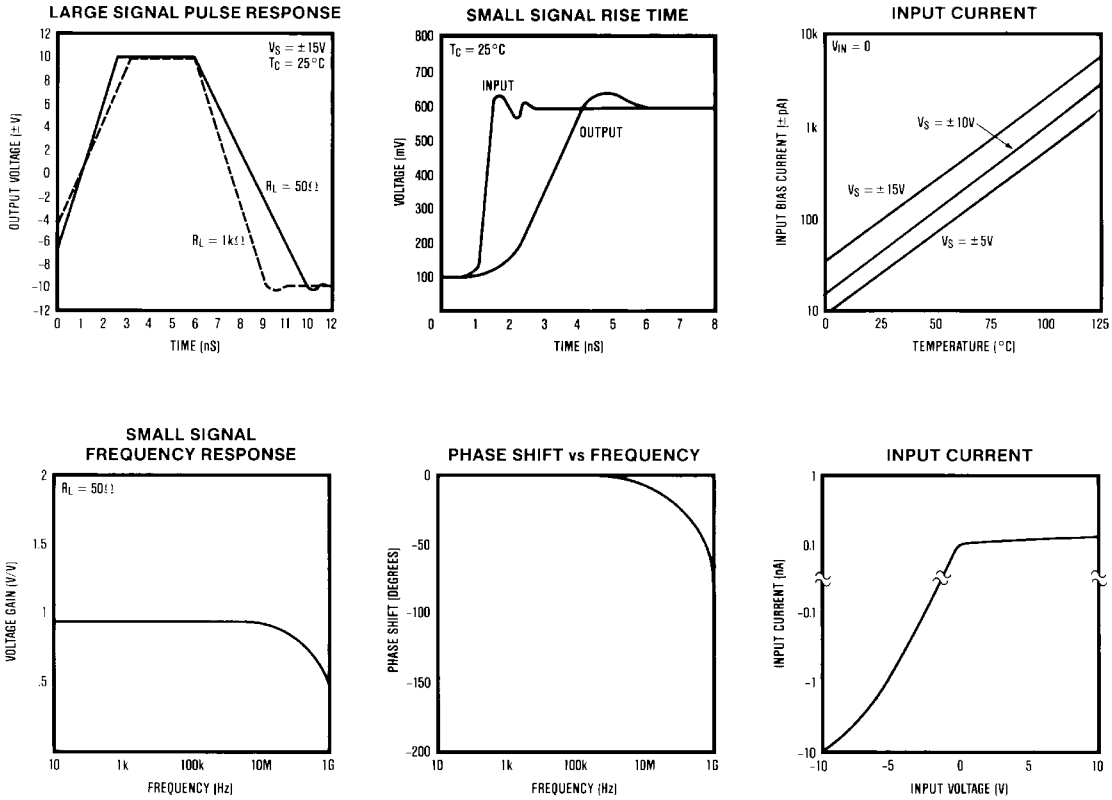

### Circuit Description

Both the BB3553 and the LH0063 consist of a complementary JFET input stage followed by a bipolar output stage. There is an inherent imbalance between the P and N channel JFETs (Q1 and Q2). Transistors Q3 and Q4 are laser trimmed current sources that correct circuit imbalances to make the offset voltage zero. On the LH0063, the negative current source is made available for optional user adjustment; the BB3553 can only be used at its factory adjusted value.

The BB3553 is internally current limited to 400mA at room temperature. This current limit is based on the  $V_{BE}$  of Q8 and Q9, so the limit point will be reduced at high temperatures. The LH0063 has no internal current limit, but has the output stage collectors brought out separately so that external current limiting can be implemented. This has the advantage that more output current is available with the LH0063, as long as the maximum power dissipation limit is not exceeded.

### Application Hints

#### Circuit Layout

Circuit layout is one of the most important areas of high frequency circuit design. Even a good circuit design may yield only marginal performance when insufficient attention is paid to circuit layout. This is especially important with very high bandwidth systems or in a closed loop system with an operational amplifier. To get full performance capability from these buffers the following circuit guidelines are suggested:

- Use a ground plane.** It provides a shielded, low-resistance, low-inductance ground reference and reduces undesirable high-frequency coupling.
- Avoid IC sockets.** The increased inter-lead capacitance can degrade bandwidth and increase feedback capacitance. Contact resistance can cause offset errors that are difficult to account for.

## Very Fast Buffer Amplifiers

3. **Keep input and output connections short.** This results in a more compact physical layout and minimizes parasitic coupling.
4. **Minimize capacitance.** When used with an op amp, minimize capacitance from output to feedback point and from feedback summing junction to ground.
5. **Keep wide traces.** Supply and output signal traces should be as wide as practical to minimize inductance and resistance.

### Power Supply Decoupling

The positive and negative power supply terminals of the devices must be bypassed to ground with solid tantalum capacitors of about 4.7μF. A somewhat larger aluminum electrolytic can be used if shunted by a high frequency capacitor with good performance at 100 MHz. In any case, the high frequency decoupling capacitors should be placed no more than ¼ to ½ inch from the device pins. These capacitors must be returned to the same ground point on the ground plane or connected by a short, wide circuit board trace of low inductance and resistance.

### Compensation

Buffer amplifiers are inherently stable in applications with resistive loads and adequate supply bypassing. However, there may be some tendency towards ringing or oscillation with capacitive loads of 100 pF or greater.

When a buffer amplifier is placed within the feedback loop of a high-gain op amp, the phase margin of the operational amplifier is reduced by an amount equal to the phase lag of the buffer at the amplifier's unity gain frequency. With most monolithic amplifiers, this will be a very small effect, but it should be considered for amplifiers active above 10MHz.

### Power Dissipation and Device Rating

The maximum junction temperature of the BB3553 or the LH0063 is 150°C. This is the basic limitation that, in conjunction with the total thermal resistance, sets the maximum allowable power dissipation for either device. Specifically,

$$P_{DISS(MAX)} = \frac{T_{J(MAX)} - T_A}{\theta_{JC} + \theta_{CS} + \theta_{SA}}$$

Where

$T_{J(MAX)}$  is the maximum allowable junction temperature of the device, e.g. 150°C

$T_A$  is the ambient temperature

$\theta_{JC}$  is the junction to case thermal resistance, 6°C/W

$\theta_{CS}$  is the thermal resistance between the device case and the heatsink in °C/W

$\theta_{SA}$  is the thermal resistance for the heatsink to ambient in °C/W.

The  $\theta_{JC}$  of the BB3553 and the LH0063 is typically 6°C/W; a conservative design should use a value of 10°C/W to allow for device-to-device variations in  $\theta_{JC}$ . The actual power dissipation in a specific application is the sum of the quiescent power dissipation (1.5W typical for the BB3553; 1.05W typical for the LH0063 assuming ±15V power supplies) and the power dissipation in the output transistors. The dissipation in the output stage is the time average of the instantaneous product of the output current times the voltage difference between the output and the supply voltages.

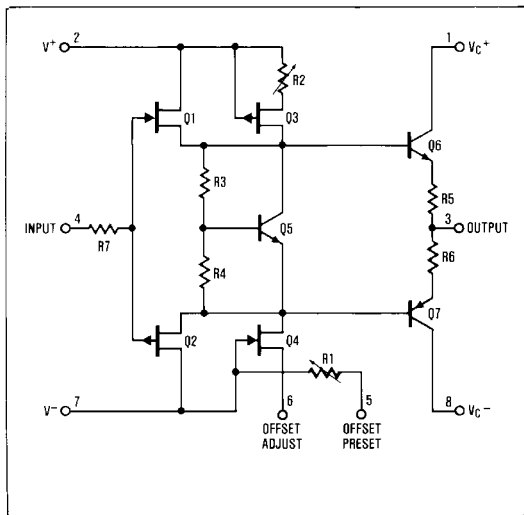

Figure 1. LH0063 Internal Structure

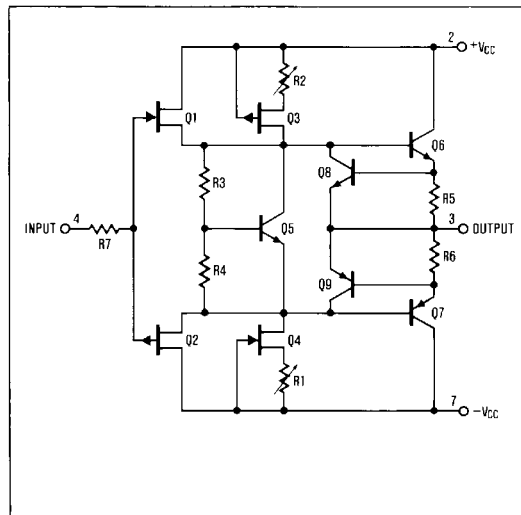

Figure 2. BB3553 Internal Structure

## Very Fast Buffer Amplifiers

### Operation from Single or Asymmetrical Power Supplies

Buffer amplifiers may be readily operated from single or asymmetrical power supplies with only a few precautions. Since the device has no ground pin and a gain of slightly less than one, an imbalance in the supplies appears to the buffer as a DC signal. It will amplify this DC signal by its gain, and will thus develop an apparent offset voltage different than the one specified in the Electrical Characteristics table. The additional output offset error may be predicted by:

$$\Delta V_O \cong (1 - A_V) \frac{(V^+ - V^-)}{2} = 0.02(V^+ - V^-)$$

where:

$A_V$  = No load voltage gain, typically 0.96

$V^+$  = Positive supply voltage

$V^-$  = Negative supply voltage

### Offset Voltage Adjustment

The normal definition of an amplifier's offset voltage is that voltage which must be applied to the input to produce zero volts at the output. This definition also applies to a buffer, but there are some other effects to consider. Most important is gain. A device that has a gain of 0.96 will develop nearly a volt of error when the input is taken to plus or minus 10V. In many applications the absolute value of the gain can be compensated.

The LH0063 has provisions for external offset voltage adjustment while the BB3553 is internally committed to its factory trimmed value. When not required, the offset adjust pins of the LH0063 must be shorted together. The external adjustment uses a 1k $\Omega$  potentiometer between pin 6 of the LH0063 and  $V^-$ . The table of DC electrical characteristics guarantees the MAXIM device to be adjustable to zero volts offset with the specified 1k $\Omega$  potentiometer.

**TABLE 1. HEATSINKS FOR LH0063/BB3553**

MANUFACTURER	PART #
Thermalloy	6002-19
IERC	LAIC3B4CB HPI-TO3-33CB

### Short Circuit Protection

The BB3553 has internal current limiting set at 400mA to protect the output stage against transient overloads. Prolonged overloads can still potentially destroy the device, depending on heat sinking and ambient conditions. The LH0063 is capable of considerably higher peak currents because it does not have the internal current limiting, but it should be externally protected if even a momentary overload is possible.

### Input Bias Current vs Input Voltage

The data sheet guarantee for input bias current and input resistance on both devices assumes an input voltage of zero volts. This is the most reasonable condition for small signal applications, but increases dramatically when the input signal swings negative. The curve of typical input current vs. input voltage illustrates the problem. In many applications, the situation can be improved by reducing the positive supply voltage.

**TABLE 2. SOCKETS FOR LH0063/BB3553**

MANUFACTURER	PART #	COMMENTS
Robinson Nugent, Inc.	0002011	Chassis or heat-sink mounted socket
Midland-Ross Hypertronics	450-3716-01-03-00 YSK0102-004	Low cost socket pins for PCB mounting. 8 socket pins are required to mount one device.

**Hypertronics**  
16 Brent Dr.  
Hudson, MA 01749  
(617) 568-0451

**IERC**  
135 W. Magnolia Bl.  
Burbank, CA 91502  
(818) 786-1182

**Midland-Ross**  
Cambion Div.  
445 Concord Ave.  
Cambridge, MA 02238  
(617) 491-5400

**Robinson-Nugent Inc.**  
800 E. 8th St.  
New Albany, IN 47150  
(812) 945-0211

**Thermalloy**  
P.O. Box 34829  
Dallas, TX 75234  
(214) 243-4321

This datasheet has been downloaded from:

[www.DatasheetCatalog.com](http://www.DatasheetCatalog.com)

Datasheets for electronic components.