

RC4151, 4152

Voltage-to-Frequency Converters

Features

- Single supply operation
- Pulse output DTL/TTL/CMOS compatible
- Programmable scale factor (K)
- High noise rejection
- Inherent monotonicity
- Easily transmittable output
- Simple full scale trim
- Single-ended input, referenced to ground
- V-F or F-V conversion
- Voltage or current input
- Wide dynamic range

Applications

- Precision voltage-to-frequency converters
- Pulse-width modulators
- Programmable pulse generators
- Frequency-to-voltage converters
- Integrating analog-to-digital converters
- Long-term analog integrators
- Signal conversion —
 - Current-to-Frequency
 - Temperature-to-Frequency
 - Pressure-to-Frequency
 - Capacitance-to-Frequency
 - Frequency-to-Current

- Signal isolation —
 - VFC — opto-isolation — FVC
 - ADC with opto-isolation
- Signal Encoding —
 - FSK modulation/demodulation
 - Pulse-width modulation
- Frequency scaling
- DC motor speed control

Description

The 4151 and 4152 are monolithic circuits containing all of the active components needed to build a complete voltage-to-frequency converter. Circuits that convert a DC voltage to a pulse train (VFC) can be built by adding a few resistors and capacitors to the internal comparator, one-shot, voltage reference, and switched current source. Frequency-to-voltage converters (FVCs) and many other signal conditioning circuits are also easily created using these converters.

Raytheon was the first company to introduce a monolithic VFC. The low cost 4151 was followed by the 4152, a pin compatible replacement offering guaranteed temperature and accuracy specifications. Both converters are available in a standard 8-pin plastic DIP.

Connection Information

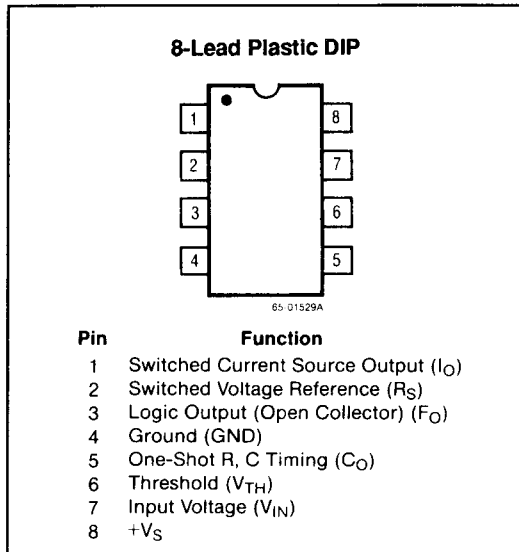

Functional Block Diagram

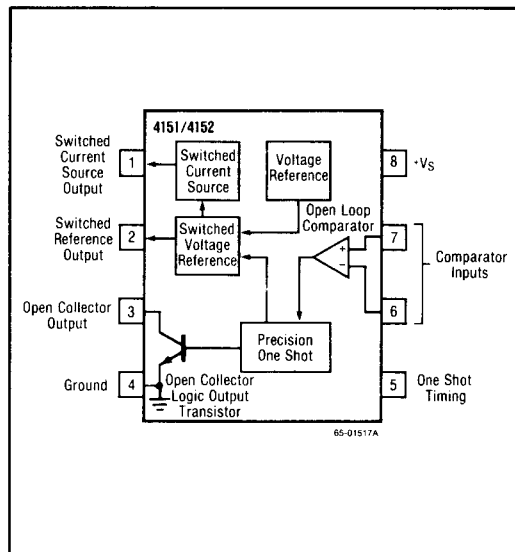

Absolute Maximum Ratings

- Supply Voltage+22V
- Internal Power Dissipation500 mW
- Input Voltage-0.2V to $+V_S$
- Output Sink Current
(Frequency Output)20 mA
- Output Short Circuit to GroundContinuous
- Storage Temperature
Range-65°C to +150°C
- Operating Temperature
Range0°C to +70°C

Ordering Information

Part Number	Package	Operating Temperature Range
RC4151N	N	0°C to +70°C
RC4152N	N	0°C to +70°C

Notes:
 N = 8- lead plastic DIP
 Contact a Raytheon sales office or representative for ordering information on special package/temperature range combinations.

Thermal Characteristics

	8-Lead Plastic DIP
Max. Junction Temp.	125°C
Max. P_D $T_A < 50^\circ\text{C}$	468 mW
Therm. Res θ_{JC}	—
Therm. Res. θ_{JA}	160°C/W
For $T_A > 50^\circ\text{C}$ Derate at	6.25 mW/°C

Electrical Characteristics ($V_S = +15V$ and $T_A = +25^\circ C$ unless otherwise noted)

Parameters	Test Conditions	4151			4152			Units
		Min	Typ	Max	Min	Typ	Max	
Power Supply Requirements (Pin 8)								
Supply Current	$V_S = +15V$		4.5	7.5		2.5	6.0	mA
Supply Voltage		+8.0	+15	+22	+7.0	+15	+18	V
Input Comparator (Pins 6 and 7)								
V_{OS}			± 2.0	± 10		± 2.0	± 10	mV
Input Bias Current			-100	-300		-50	-300	nA
Input Offset Current			± 50	± 100		± 30	± 100	nA
Input Voltage Range		0	$V_S - 2$	$V_S - 3$	0	$V_S - 2$	$V_S - 3$	V
One Shot (Pin 5)								
Threshold Voltage		0.63	0.67	0.70	0.65	0.67	0.69	XV_S
Input Bias Current			-100	-500		-50	-500	nA
Saturation Voltage	$I = 2.2mA$		0.15	0.5		0.1	0.5	V
Drift of Timing vs. Temperature ²	$T = 75\mu S$ $0^\circ C$ to $+70^\circ C$		± 35			± 30	± 50	ppm/ $^\circ C$
Drift of Timing vs. Supply			± 150			± 100		ppm/V
Switched Current Source ¹ (Pin 1)								
Output Current	4151- $R_S = 14.0K$ / 4152- $R_S = 16.7K$		+138			+138		μA
Drift vs. Temperature ²	$0^\circ C$ to $+70^\circ C$		± 75			± 50	± 100	ppm/ $^\circ C$
Drift vs. Supply Voltage			0.15			0.10		%/V
Leakage Current	Off State		1.0	50		1.0	50	nA
Compliance	Pin 1 = 0V to +10V	1.0	2.5		1.0	2.5		μA
Reference Voltage (Pin 2)								
V_{REF}		1.7	1.9	2.08	2.0	2.25	2.5	V
Drift vs. Temperature ²	$0^\circ C$ to $+70^\circ C$		± 50			± 50	± 100	ppm/ $^\circ C$
Logic Output (Pin 3)								
Saturation Voltage	$I_{SINK} = 3.0mA$		0.1	0.5		0.1	0.5	V
Saturation Voltage	$I_{SINK} = 10mA$		0.8			0.8		V
Leakage Current	Off State		0.2	1.0		0.1	1.0	μA
Nonlinearity % Error Voltage Sourced Circuit of Figure 3	1.0Hz to 10kHz		0.013			0.007	0.05	%
Temperature Drift Voltage ² Sourced Circuit of Figure 3	$0^\circ C$ to $+70^\circ C$ $F_0 = 10kHz$		± 100			± 75	± 150	ppm/ $^\circ C$

Notes:

1. Temperature coefficient of output current source (pin 1 output) exclusive of reference voltage drift.
2. Guaranteed but not tested.

Typical Performance Characteristics

10kHz Current-Sourced VFC Nonlinearity

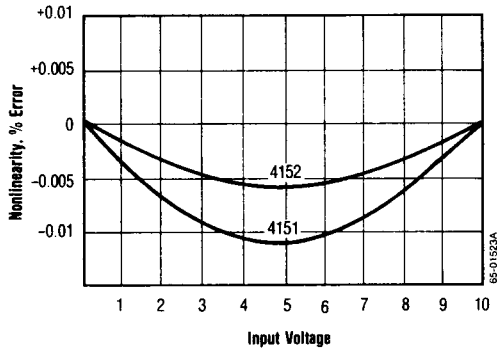

100kHz Current-Sourced VFC Nonlinearity

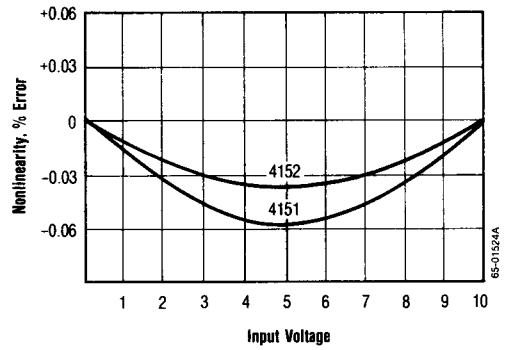

10kHz Voltage-Sourced VFC Nonlinearity

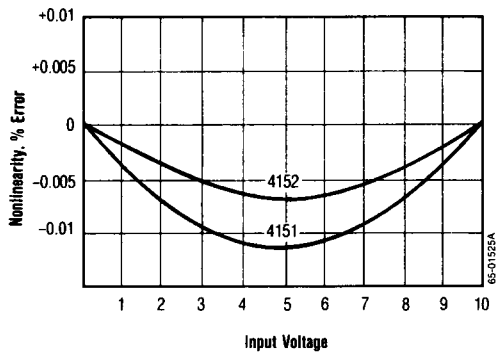

100kHz Voltage-Sourced VFC Nonlinearity

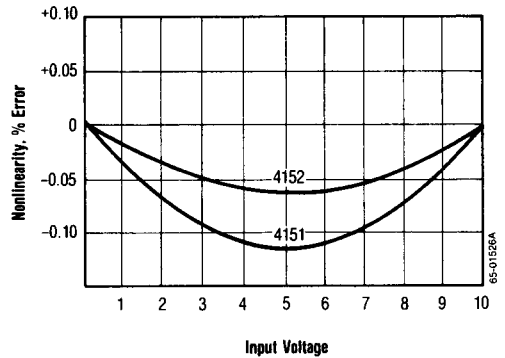

10kHz Precision FVC Nonlinearity

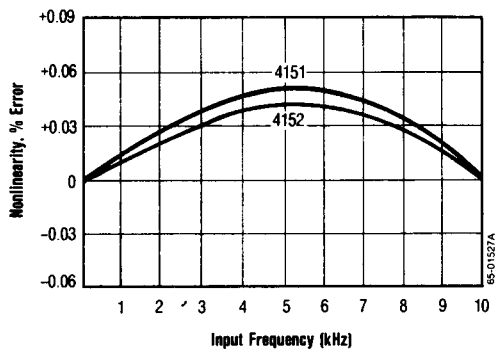

100kHz Precision FVC Nonlinearity

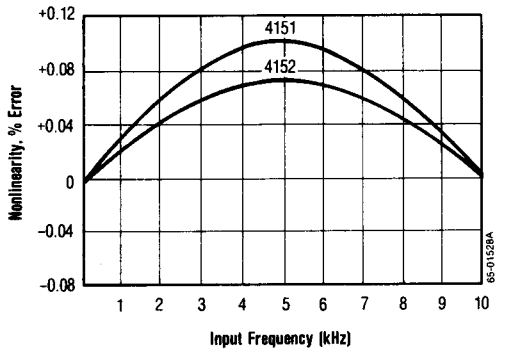

Principles of Operation

The 4151 and the 4152 contain the following components: an open loop comparator, a precision one-shot timer, a switched voltage reference, a switched current source, and an open collector logic output transistor. These functional blocks are internally interconnected in a special way. By adding some external resistors and capacitors, a designer can create a complete voltage-to-frequency converter.

The comparator's output controls the one-shot (monostable timer). The one-shot in turn controls the switched current source, the switched reference, and the open collector output transistor. The block diagram shows the components and their interconnection.

To detail, if the voltage at pin 7 is greater than the voltage at pin 6, the comparator switches and triggers the one-shot. When the one-shot is triggered, two things happen. First, the one-shot begins its timing period. Second, the one-shot's output turns on the switched current source, the switched voltage reference, and the open collector output transistor.

The one-shot creates its timing period much like the popular 555 timer does, by charging a capacitor from a resistor tied to $+V_S$. The one-shot

senses the voltage on the capacitor (pin 5) and ends the timing period when the voltage reaches $2/3$ of the supply voltage. At the end of the timing period the capacitor is discharged by a transistor similar to the open collector output transistor.

Meanwhile, during the timing period of the one-shot, the switched current source, the switched reference, and the open collector output transistor all will be switched on. The switched current source (pin 1) will deliver a current proportional to both the reference voltage and an external resistor, R_S . The switched reference (pin 2) will supply an output voltage equal to the internal reference voltage (4151 = 1.9V, 4152 = 2.25V). The open collector output transistor will be turned on, forcing the logic output (pin 3) to a low state. At the end of the timing period all of these outputs will turn off. The switched voltage reference has produced an off-on-off voltage pulse, the switched current source has emitted a quanta of charge, and the open collector output has transmitted a logic pulse.

To summarize, the purpose of the circuit is to produce a current pulse, well-defined in amplitude and duration, and to simultaneously produce an output pulse which is compatible with most logic families. The circuit's outputs show a pulse waveform in response to a voltage difference between the comparator's inputs.

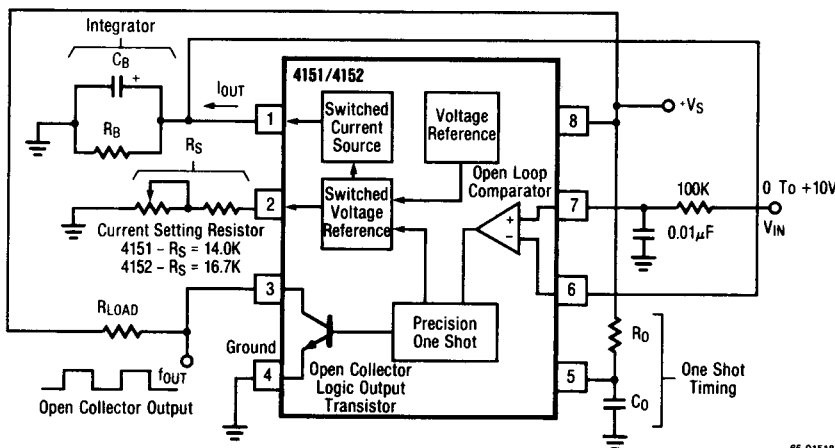

65-01518B

Figure 1. Single Supply VFC

Applications

Single Supply VFC

The stand-alone voltage-to-frequency converter is one of the simplest applications for the 4151 or 4152. This application uses only passive external components to create the least expensive VFC circuit.

The positive input voltage V_{IN} is applied to the input comparator through a low pass filter. The one-shot will fire repetitively and the switched current source will pump out current pulses of amplitude V_{REF}/R_S and duration $1.1 R_O C_O$ into the integrator. Because the integrator is tied back to the inverting comparator input, a feedback loop is created. The pulse repetition rate will increase until the average voltage on the integrator is equal to the DC input voltage at pin 7. The average voltage at pin 6 is proportional to the output frequency because the amount of charge in each current pulse is precisely controlled.

Because the one-shot firing frequency is the same as the open collector output frequency, the output frequency is directly proportional to V_{IN} .

The external passive components set the scale factor. For best linearity, R_S should be limited to a range of $12k\Omega$ to $20k\Omega$.

The reference voltage is nominally 1.9V for the 4151 and 2.25V for the 4152. Recommended values for different operating frequencies are shown in the table below.

Operating Range	R_O	C_O	R_B	C_B
DC to 1.0kHz	6.8k Ω	0.1 μ F	100k Ω	10 μ F
DC to 10kHz	6.8k Ω	0.01 μ F	100k Ω	1.0 μ F
DC to 100kHz	6.8k Ω	0.001 μ F	100k Ω	0.1 μ F

The single supply VFC is recommended for uses where the dynamic range of the input is limited, and the input does not reach 0V. With 10kHz values, nonlinearity will be less than 1.0% for a 10mV to 10V input range, and response time will be about 135mS.

Precision Current-Sourced VFC

This circuit operates similarly to the single supply VFC, except that the passive R-C integrator has been replaced by an active op amp integrator. This

increases the dynamic range down to 0V, improves the response time, and eliminates the nonlinearity error introduced by the limited compliance of the switched current source output.

The integrator algebraically sums the positive current pulses from the switched current source with the current V_{IN}/R_B . To operate correctly, the input voltage must be negative, so that when the circuit is balanced, the two currents cancel.

$$T = \frac{1}{F_{OUT}}$$

$$\frac{|V_{IN}|}{R_B} = I_{OUT} \left[\frac{T_P}{T} \right] \text{ where } T_P = 1.1 R_O C_O$$

$$I_{OUT} = \frac{V_{REF}}{R_S}$$

By rearranging and substituting,

$$F_{OUT} = \left[\frac{R_S}{1.1 R_O C_O R_B} \right] \left[\frac{V_{IN}}{V_{REF}} \right]$$

Recommended component values for different operating frequencies are shown in the table below.

Range		Scale Factor	R_O	C_O	C_I	R_B
Input V_{IN}	Output F_O					
0 to -10V	0 to 1.0kHz	0.1kHz/V	6.8k Ω	0.1 μ F	0.05 μ F	100k Ω
0 to -10V	0 to 10kHz	1.0kHz/V	6.8k Ω	0.01 μ F	0.005 μ F	100k Ω
0 to -10V	0 to 100kHz	10kHz/V	6.8k Ω	1000pF	500pF	100k Ω

The graphs shown under Typical Performance Characteristics show nonlinearity versus input voltage for the precision current-sourced VFC. The 4152s improved circuitry reduces nonlinearity error when compared to the 4151. The best linearity is achieved by using an op amp having greater than 1.0V/ μ S slew rate, but any op amp can be used.

Precision Voltage-Sourced VFC

This circuit is identical to the current-sourced VFC, except that the current pulses into the integrator are derived directly from the switched voltage reference. This improves temperature drift at the expense of high frequency linearity.

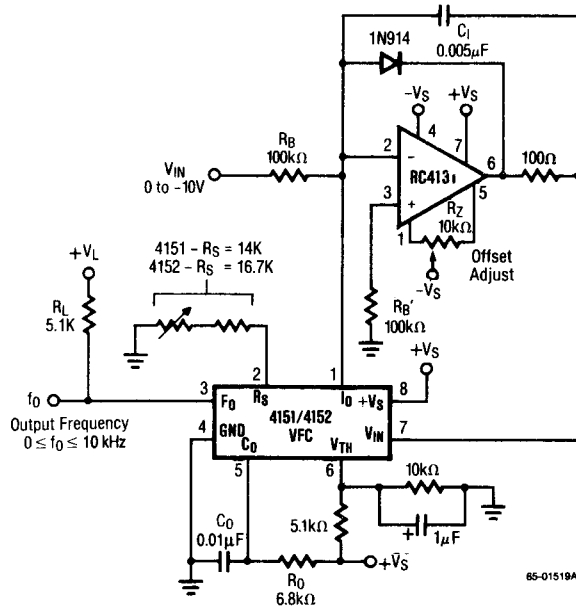

Figure 2. Precision Current — Sourced VFC

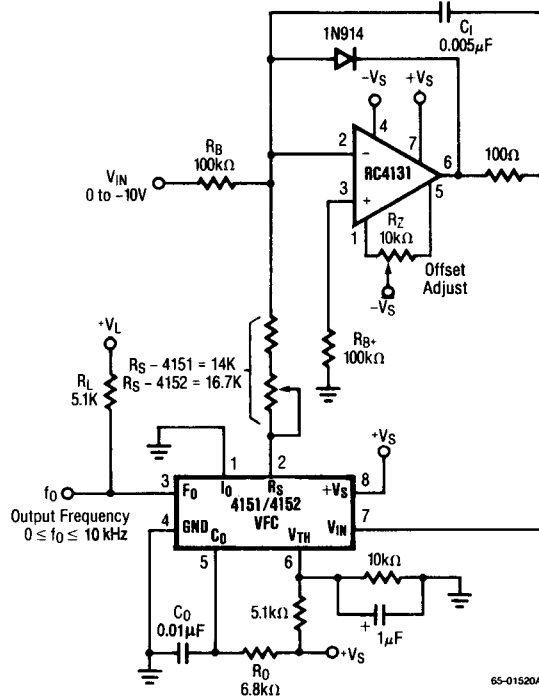

Figure 3. Precision Voltage — Sourced VFC

The switched current source (pin 1) output has been tied to ground, and R_S has been put in series between the switched voltage reference (pin 2) and the summing node of the op amp. This eliminates temperature drift associated with the switched current source. The graphs under the Typical Performance Characteristics show that the nonlinearity error is worse at high frequency, when compared with the current-sourced circuit.

Single Supply FVC

A frequency-to-voltage converter performs the exact opposite of the VFCs function; it converts an input pulse train into an average output voltage. Incoming pulses trigger the input comparator and fire the one-shot. The one-shot then dumps a charge into the output integrator. The voltage on the integrator becomes a varying DC voltage proportional to the frequency of the input signal. Figure 4 shows a complete single supply FVC.

The input waveform must have fast slewing edges, and the differentiated input signal must be less than the timing period of the one-shot, $1.1 R_O C_O$. A differentiator and divider are used to shape and bias the trigger input; a negative going pulse at pin 6 will cause the comparator to fire the one-shot. The input pulse amplitude must be large enough to trip the comparator, but not so large as to exceed the ICs input voltage ratings.

The output voltage is directly proportional to the input frequency:

$$V_O = \left[\frac{1.1 R_O C_O R_B V_{REF}}{R_S} \right] f_{IN} \text{ (Hz)}$$

Output ripple can be minimized by increasing C_B , but this will limit the response time. Recommended values for various operating ranges are shown in the table below.

Input Operating Range	C_{IN}	R_O	C_O	R_B	C_B	Ripple
0 to 1.0kHz	0.02 μ F	6.8k Ω	0.1 μ F	100k Ω	100 μ F	1.0mV
0 to 10kHz	0.002 μ F	6.8k Ω	0.01 μ F	100k Ω	10 μ F	1.0mV
0 to 100kHz	200pF	6.8k Ω	0.001 μ F	100k Ω	1.0 μ F	1.0mV

Precision FVC

Linearity, offset, and response time can be improved by adding one or more op amps to form an active lowpass filter at the output. A circuit using a single pole active integrator is shown in Figure 5.

The positive output current pulses are averaged by the inverting integrator, causing the output voltage to be negative. Response time can be further improved by adding a double pole filter to replace the single pole filter. Refer to the graphs under Typical Performance Characteristics that show nonlinearity error versus input frequency for the precision FVC circuit.

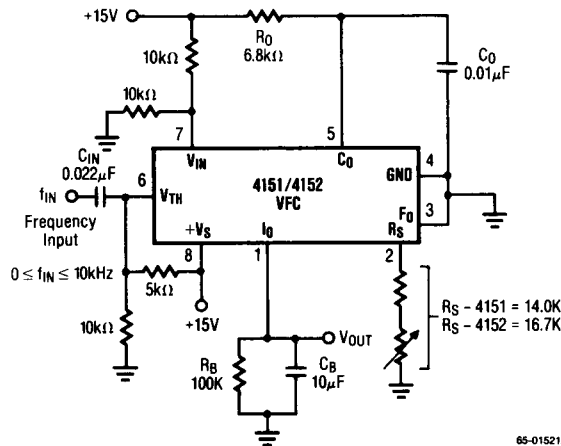
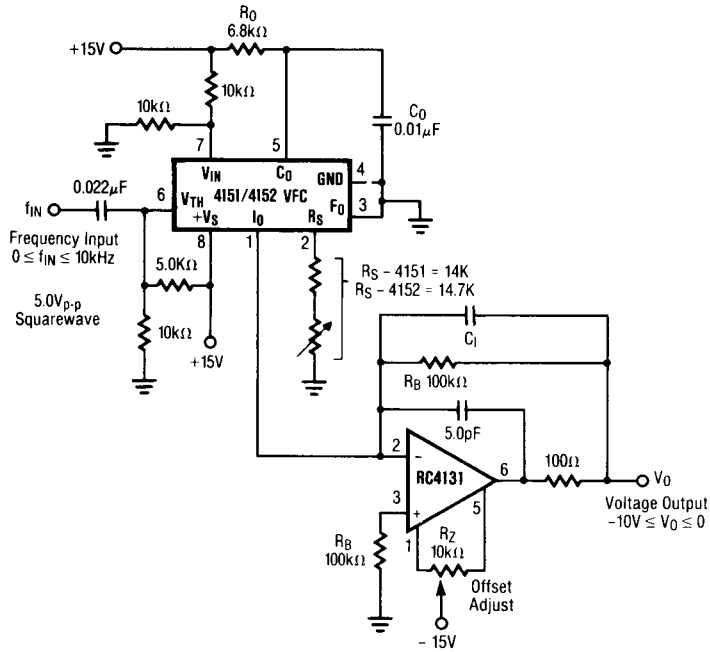

Figure 4. Single Supply FVC



65-01522A

Figure 5. Precision VFC

Mask Pattern

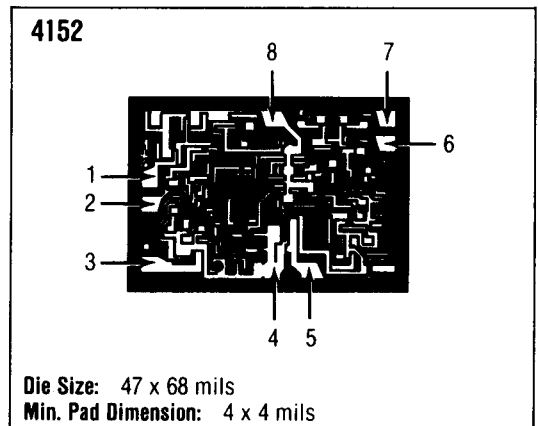
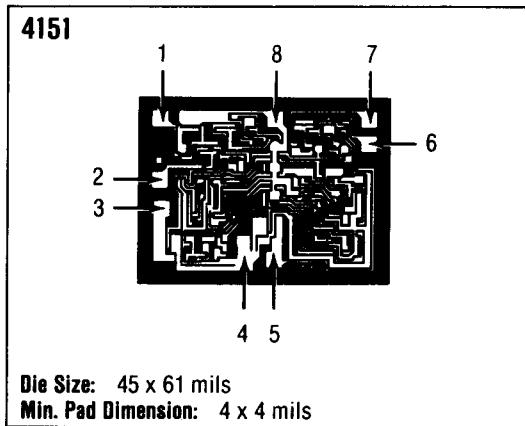

Schematic Diagram — 4151

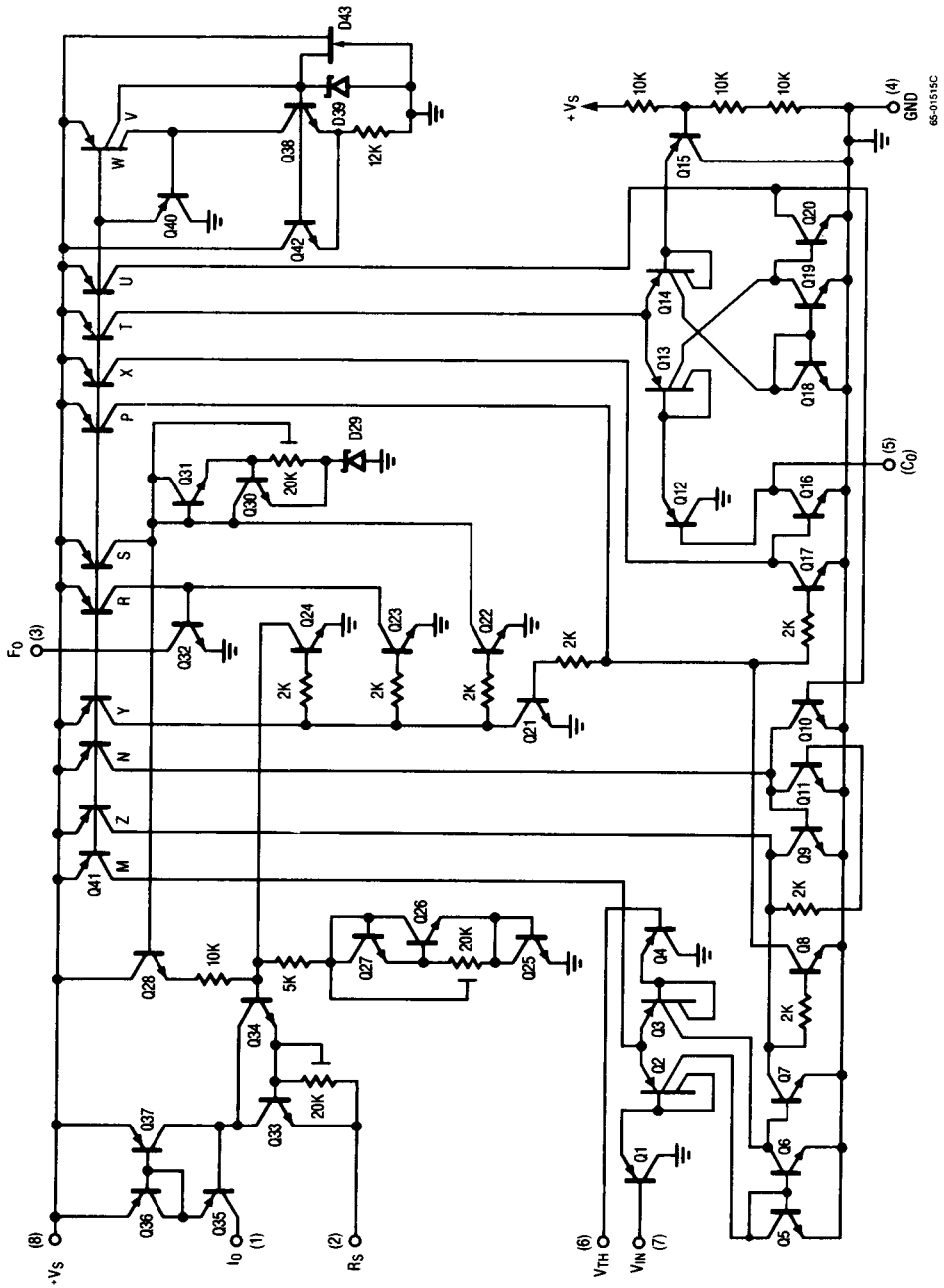

Schematic Diagram — 4152

