

HIGH PERFORMANCE MOTOR SPEED REGULATOR

- TACHIMETRIC SPEED REGULATION WITH NO NEED FOR AN EXTERNAL SPEED PICK-UP
- V/I SUPPLEMENTARY PREREGULATION
- DIGITAL CONTROL OF DIRECTION AND MOTOR STOP
- SEPARATE SPEED ADJUSTMENT
- 5.5V TO 18V OPERATING SUPPLY VOLTAGE
- 1A PEAK OUTPUT CURRENT
- OUTPUT CLAMP DIODES INCLUDED
- SHORT CIRCUIT CURRENT PROTECTION
- THERMAL SHUT DOWN WITH HYSTERESIS
- DUMP PROTECTION (40V)
- ESD PROTECTION

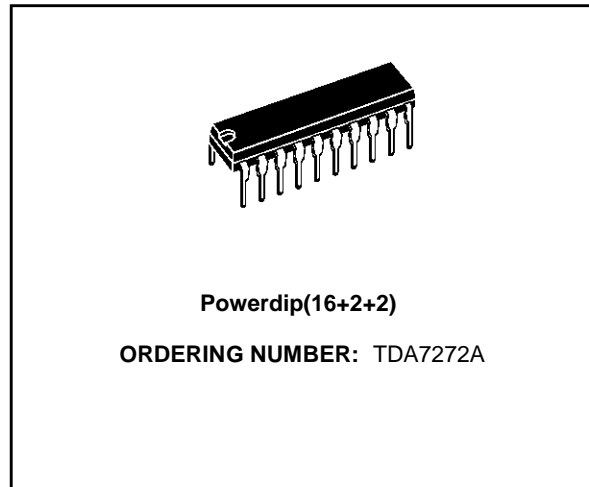

DESCRIPTION

TDA7272A are high performance motor speed controller for small power DC motors as used in cassette players.

Using the motor as a digital tachogenerator itself the performance of true tacho controlled systems is reached.

A dual loop control circuit provides long term stability and fast settling behaviour.

BLOCK DIAGRAM

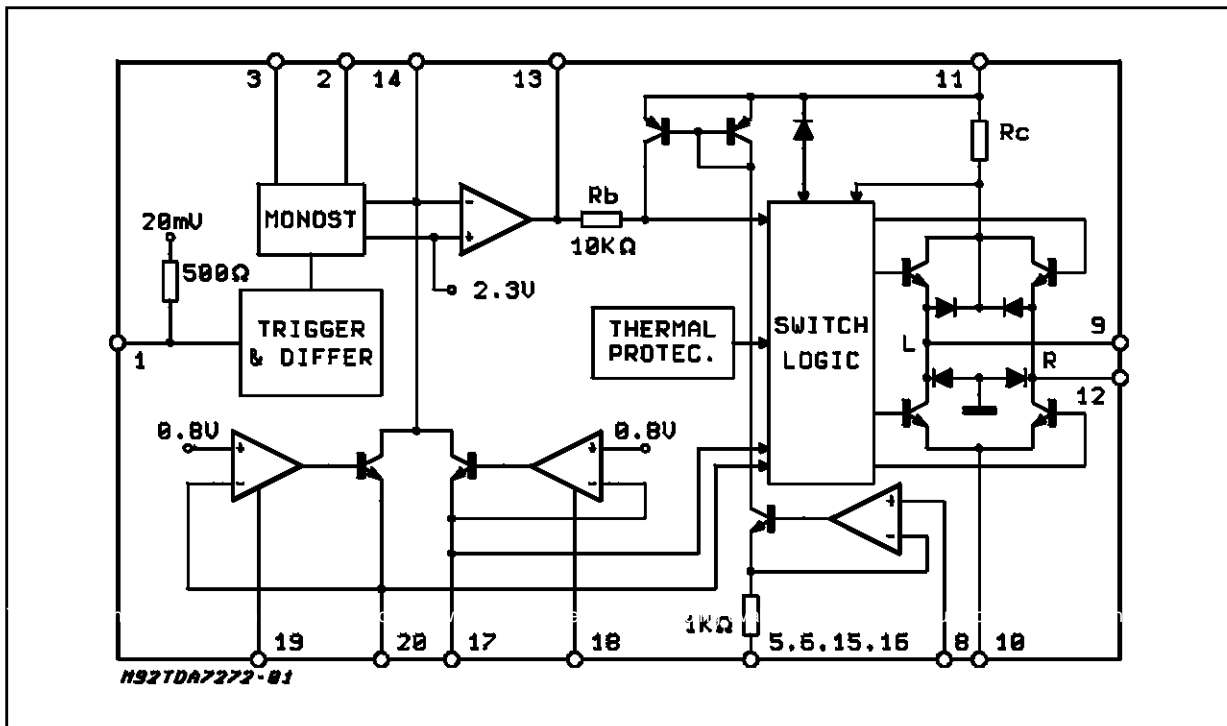

TDA7272A

ABSOLUTE MAXIMUM RATINGS

Symbol	Parameter	Value	Unit
V_S	DC Supply Voltage	24	V
V_S	Dump Voltage (300ms)	40	V
I_O	Output Current	Internally limited	
P_{tot}	Power Dissipation at $T_{pins} = 90^\circ\text{C}$ at $T_{amb} = 70^\circ\text{C}$	4.3	W
		1	W
T_{op}	Operating Temperature Range	-40 to 85	$^\circ\text{C}$
T_{stg}	Storage Temperature	-40 to 150	$^\circ\text{C}$

PIN CONNECTION (Top view)

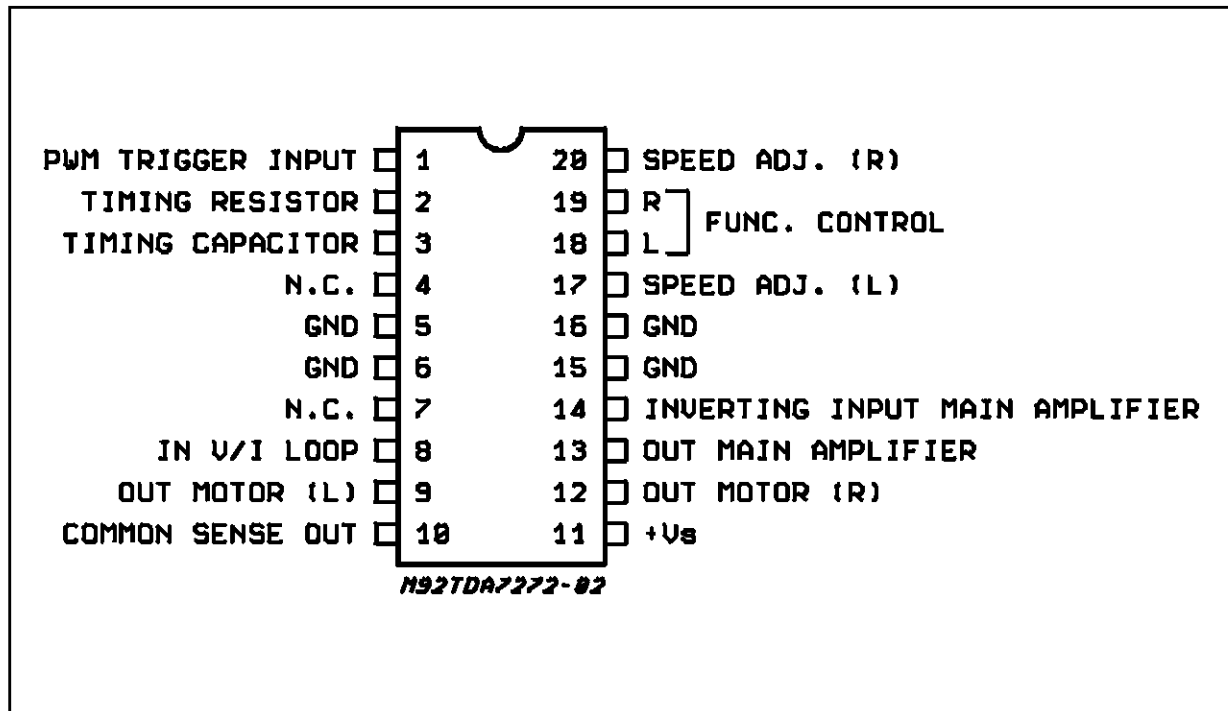

THERMAL DATA

Symbol	Parameter	Value	Unit
$R_{th\ j-amb}$	Thermal Resistance Junction-ambient	max. 80	$^\circ\text{C}/\text{W}$
$R_{th\ j-pins}$	Thermal Resistance Junction-pins	max. 14	$^\circ\text{C}/\text{W}$

TEST CIRCUIT

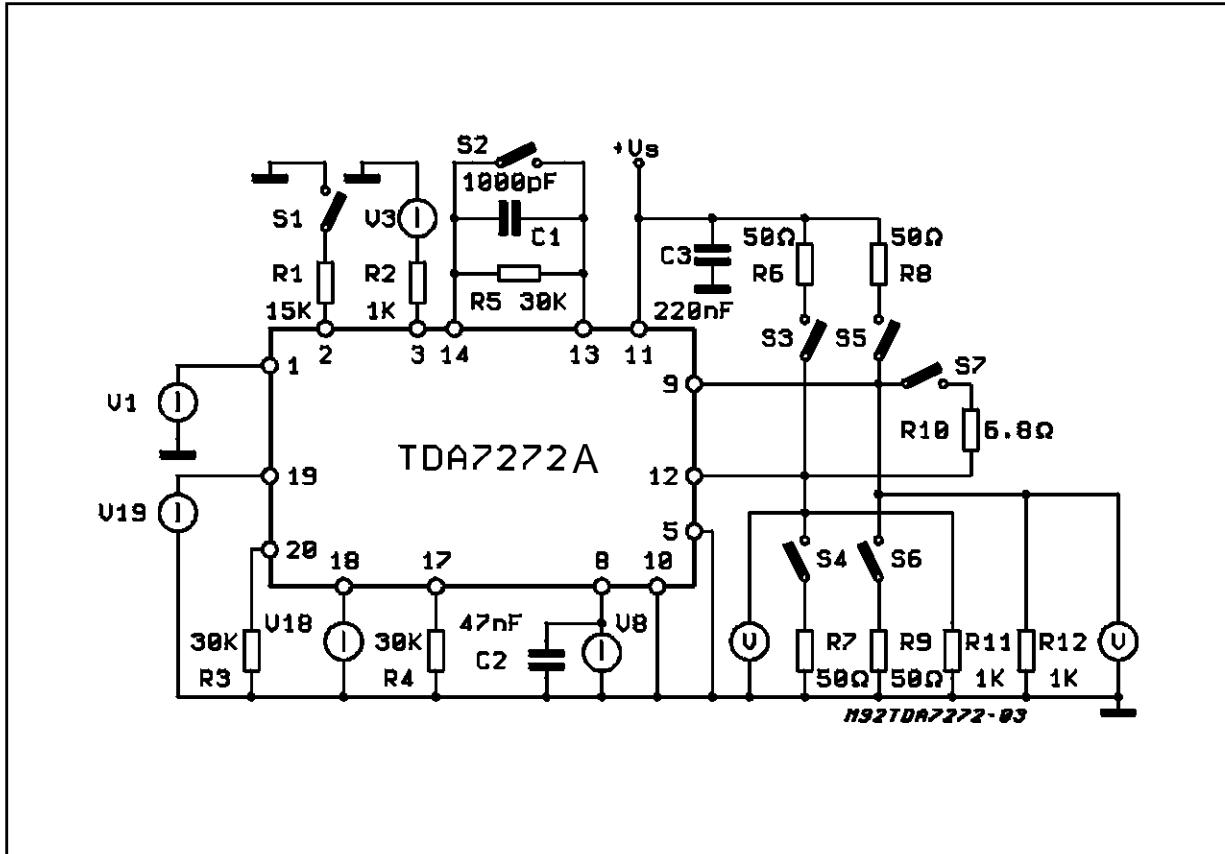
ELECTRICAL CHARACTERISTICS ($T_{amb} = 25^{\circ}\text{C}$; $V_S = 13.5\text{V}$ unless otherwise specified)

Symbol	Parameter	Test Conditions	Min.	Typ.	Max.	Unit
V_S	Operating Supply Voltage		5.5		18	V
I_S	Supply Current	No load		5	12	mA
OUTPUT STAGE						
I_O	Output Current Pulse		1			A
I_O	Output Current Continuous		250			mA
$V_{10,9,12}$	Voltage Drop	$I_O = 250\text{mA}$		1.2	1.5	V
$V_{11,9,12}$	Voltage Drop	$I_O = 250\text{mA}$		1.7	2	V
MAIN AMPLIFIER						
R_{14}	Input Resistance		100			$\text{K}\Omega$
I_b	Bias Current			50		nA
V_{OFF}	Offset Voltage			1	5	mV
V_R	Reference Voltage	Internal at non inverting input		2.3		V

ELECTRICAL CHARACTERISTICS (Continued)

Symbol	Parameter	Test Conditions	Min.	Typ.	Max.	Unit
CURRENT SENSE AMPLIFIER						
R_8	Input Resistance		100			$K\Omega$
G_L	Loop Gain			9		
TRIGGER AND MONOSTABLE STAGE						
V_{IN1}	Input Allowed Voltage		-0.7		3	V
R_{IN1}	Input Resistance			500		Ω
$V_{T\ Low}$	Trigger Level			0		V
$V_{T\ B}$	Bias Voltage (pin 1)		15	20	25	mV
$V_{T\ H}$	Trigger Hysteresis			10		mV
$V_{2\ REF}$	Reference Voltage		750	800	850	mV
SPEED PROGRAMMING, DIRECTION CONTROL LOGIC AND CURRENT SOURCE PROGRAMMING						
$V_{18,19\ Low}$	Input Low Level				0.7	V
$V_{18,19\ High}$	Input High Level		2			V
$I_{18,19}$	Input Current	$0 < V_{18,19} < V_S$		2		μA
$V_{17,20\ REF}$	Reference Voltage		735	800	865	mV

The TDA7272A novel applied solution is based on a tachometer control system without using such extra tachometer system. The information of the actual motor speed is extracted from the motor itself. A DC motor with an odd number of poles generates a motor current which contains a fixed number of discontinuities within each rotation. (6 for the 3 pole motor example on fig. 1)

Deriving this inherent speed information from the motor current, it can be used as a replacement of a low resolution AC tachometer system. Because the settling time of the control loop is limited on principle by the resolution in time of the tachome-

ter, this control principle offers a poor reaction time for motors with a low number of poles. The realized circuit is extended by a second feed forward loop in order to improve such system by a fast auxiliary control path.

This additional path senses the mean output current and varies the output voltage according to the voltage drop across the inner motor resistance. Apart from a current averaging filter, there is no delay in such loop and a fast settling behaviour is reached in addition to the long term speed motor accuracy.

Figure 1: Equivalent of a 3 Pole DC Motor (a) and Typical motor Current Waveform (b).

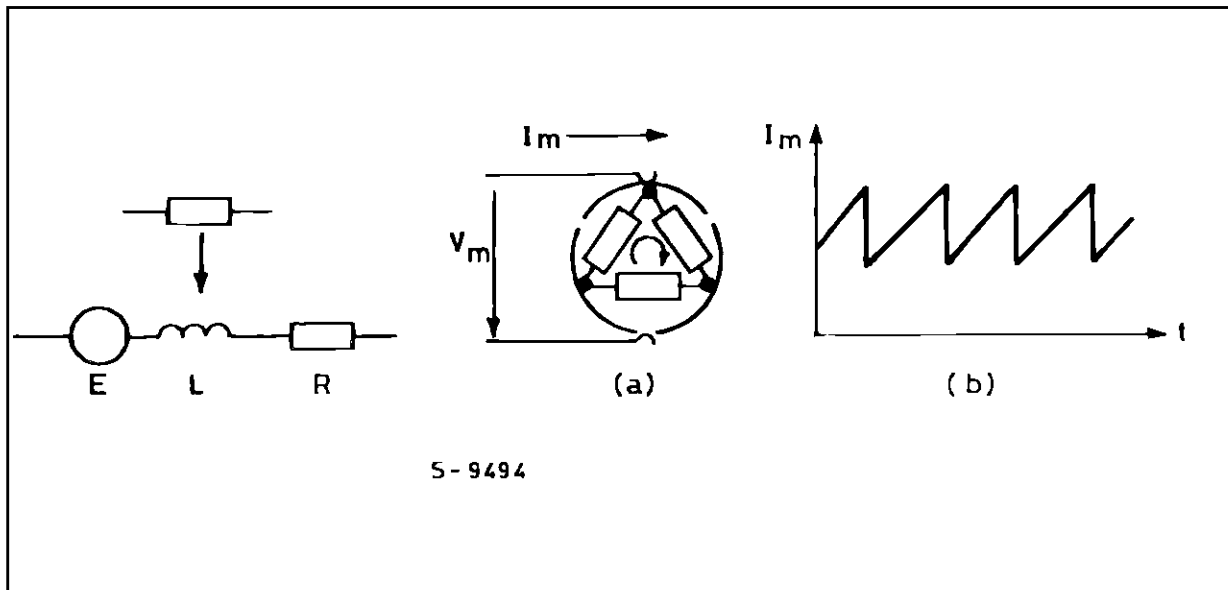

BLOCK DESCRIPTION

The principle structure of the element is shown in fig. 2. As to be seen, the motor speed information is derived from the motor current sense drop across the resistors R_S ; capacitor CD together with the input impedance of 500 Ω at pin 1 realizes a high pass filter.

This pin is internally biased at 20 mV, each negative zero transition switches the input comparator. A 10 mV hysteresis improves the noise immunity.

The trigger circuit is followed by an internal delay time differentiator.

Thus, the system becomes widely independent of the applied waveform at pin 1, the differentiator triggers a monostable circuit which provides a constant current duration. Both, output current magnitude and duration T, are adjustable by ex-

ternal elements CT and RT.

The monostable is retriggerable; this function prevents the system from fault stabilization at higher harmonics of the nominal frequency.

The speed programming current is generated by two separate external adjustable current sources. A corresponding digital input signal enables each current source for left or right rotation direction. Resistor RP1 and RP2 define the speed, the logical inputs are at pin 18 and 19.

At the inverting input (pin 14) of the main amplifier the reference current is compared with the pulsed monostable output current.

For the correct motor speed, the reference current matches the mean value of the pulsed monostable current. In this condition the charge of the feedback capacitor becomes constant.

Figure 2: Application Circuit.

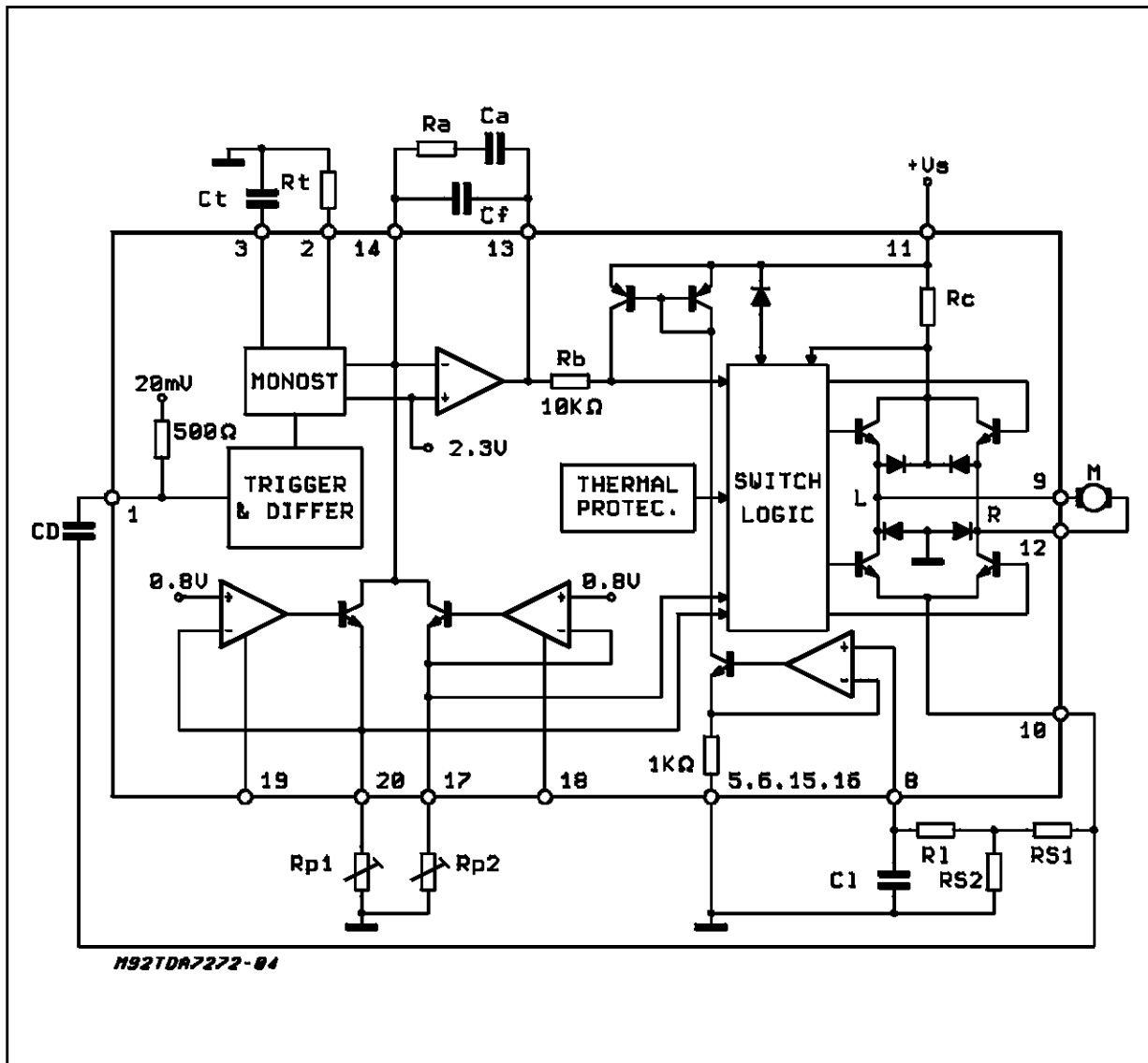

The speed n of a k pole motor results :

$$n = \frac{10.435}{C_T k R_P}$$

and becomes independent of the resistor R_T which only determines the current level and the duty cycle which should be 1 : 1 at the nominal speed for minimum torque ripple.

The second fast loop consists of a voltage to current converter which is driven at pin 8 by the low pass filter R_L, C_L . The output current at this stage is injected by a PNP current mirror into the inner resistor R_B . So the driving voltage of the output stage consists of the integrator output voltage plus the fast loop voltage contribution across R_B .

The power output stage realizes different modes depending on the logic status at pin 18 and 19.

- Normal operation for left and right mode : each upper TR of the bridge is used as voltage follower whereas the lower acts as a switch.
- Stop mode where the upper half is open and the lower is conductive.
- High impedance status where all power elements are switched-off.

The high impedance status is also generated when the supply voltage overcomes the 5 V to 20 V operating range or when the chip temperature exceeds 150 °C.

A short circuit protection limits the output current at 1.5 A. Integrated diodes clamp spikes from the inductive load both at V_{CC} and ground.

The reference voltages are derived from a common bandgap reference. All blocks are widely supplied by an internal 3.5 V regulator which provides a maximum supply voltage rejection.

PIN FUNCTION AND APPLICATION INFORMATION

PIN 1

Trigger input. Receives a proper voltage which contains the information of the motor speed. The waveform can be derived directly by the motor current (fig. 3). The external resistor generates a proper voltage drop. Together with the input resistance at pin 1 [$R_{IN}(1) = 500 \Omega$] the external capacitor C_D realize a high pass filter which differentiates the commutation spikes of the motor current. The trigger level is 0V.

The biasing of the pin 1 is 20 mV with a hysteresis of 10 mV. So the sensing resistance must be chosen high enough in order to obtain a negative spike of the least 30 mV on pin 1, also with minimum variation of motor current :

$$R_S \geq \frac{30mV}{\Delta I_{MOT \min}}$$

Such value can be too much high for the preregulation stage V-I and it could be necessary to split

Figure 3.

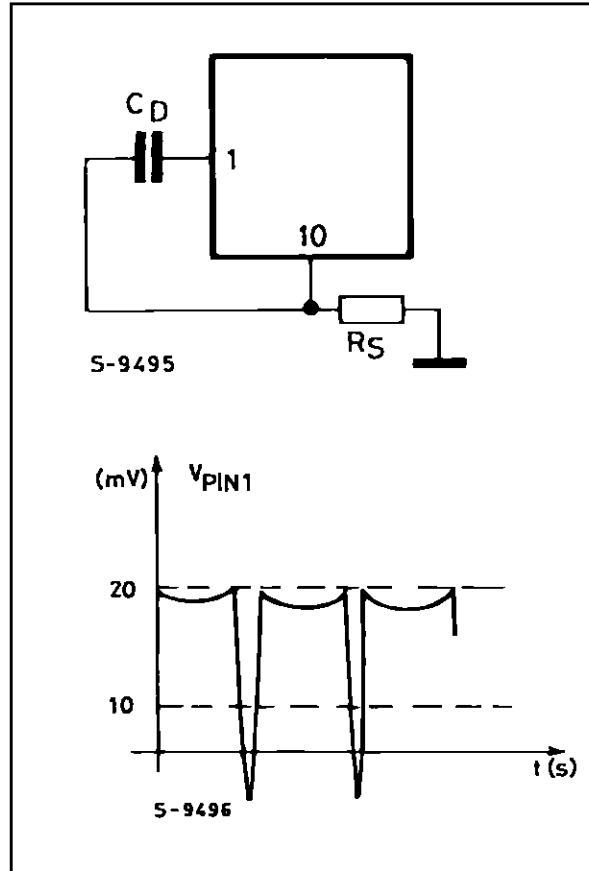
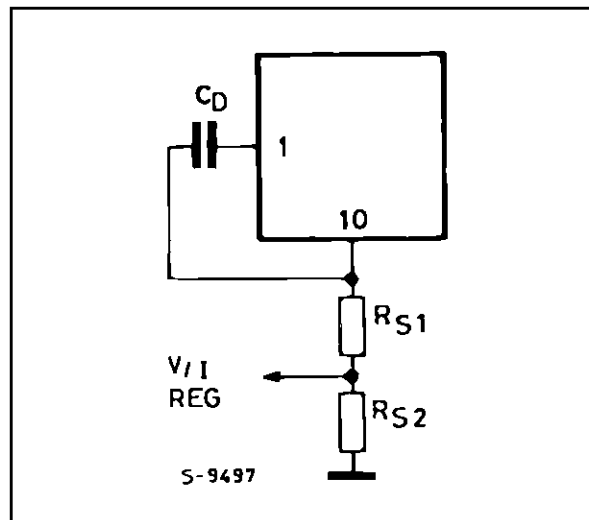

Figure 4.



them into 2 series resistors $R_S = R_{S1} + R_{S2}$ (see fig. 4) as explained on pin 8 section.

The information can be taken also from an external tachogenerator. Fig. 5 shows various sources connections :

the input signal mustn't be lower than 0.7 V.

Figure 5.

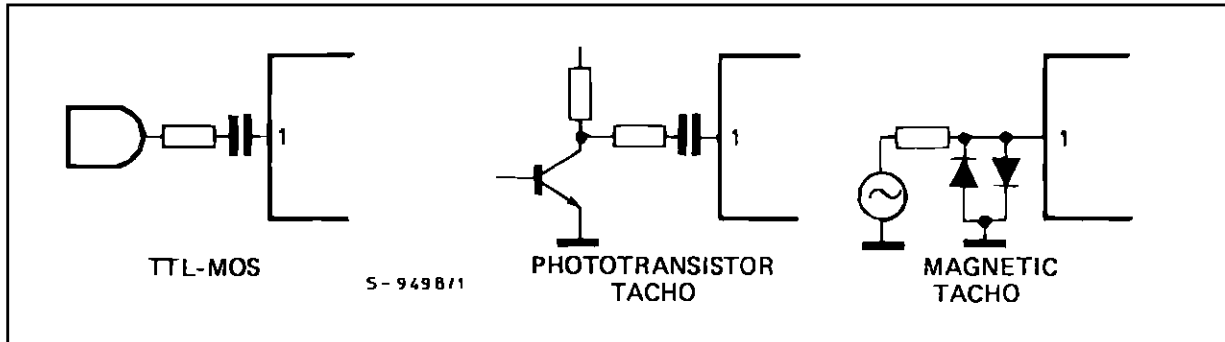

Pin 2

Timing resistor. An internal reference voltage ($V_2 = 0.8\text{ V}$) gives possibility to fix by an external resistor (R_T), from this pin and ground, the output current amplitude of the monostable circuit, which will be reflected into the timing capacitor (pin 3) ; the typical value would be about $50\ \mu\text{ A}$.

Figure 6.

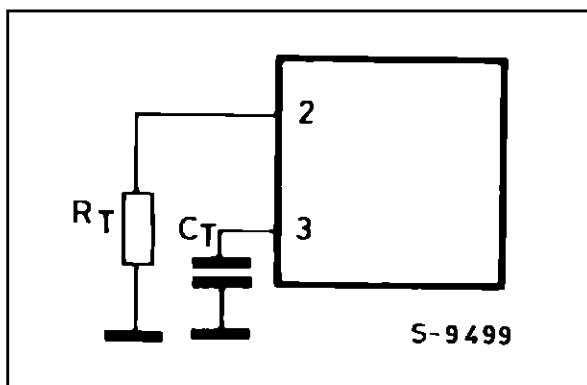

Pin 3

Timing capacitor. A constant current, determined by the pin 2 resistor, flowing into a capacitor between pin 3 and ground provides the output pulse width of the monostable circuit, the max voltage at pin 3 is fixed by an internal threshold : after reaching this value the capacitor is rapidly discharged and the pulse width is fixed to the value :

$$T_{on} = 2.88 R_T C_T \text{ (fig. 6)}$$

Pin 4

Not connected.

Pin 5

Ground. Connected with pins 6, 15, 16.

Pin 6

Ground. Connected with pins 5, 15, 16.

Pin 7

Not connected.

Pin 8

Input V/I loop. Receives from pin 10, through a low pass filter, the voltage with the information of the current flowing into the motor and produces a negative resistance output :

$$R_{out} = -9 R_s \text{ (fig. 7)}$$

Figure 7.

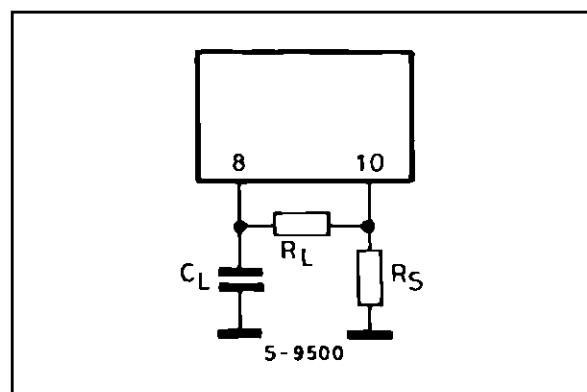

For compensating the motor resistance and avoiding instability :

$$R_s \leq \frac{R_{MOTOR}}{9}$$

The optimization of the resistor R_s for the tachometric control must not give a voltage too high for the V/I stage : one solution can be to divide in two parts, as shown in fig. 8, with :

$$R_{s2} = \frac{R_M}{10} \text{ and } R_{s1} + R_{s2} \geq \frac{30\text{mV}}{\Delta I \text{ mot min.}}$$

(see pin 1 sect.)

The low pass filter R_L, C_L must be calculated in order to reduce the ripple of the motor commutation at least 20 dB. Another example of possible pins 10-8 connections is showed on fig. 9. A choke can be used in order to reduce the radiation.

Figure 8.

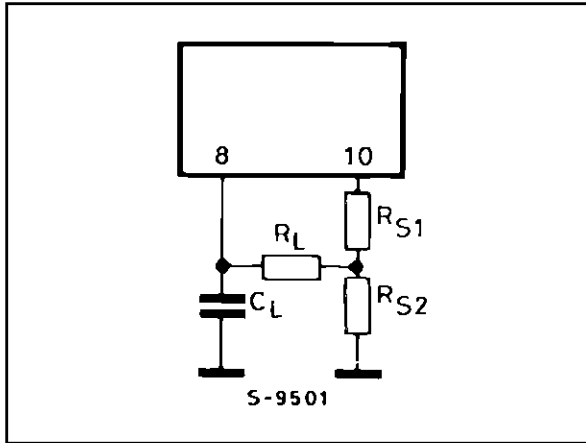
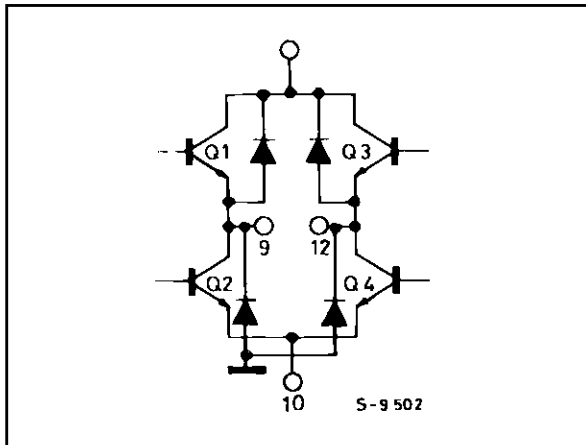

Figure 9.



Pin 9

Output motor left. The four power transistors are realized as darlington structures. The arrangement is controlled by the logic status at pins 18 and 19.

As before explained (see block description), in the normal left or right mode one of the lower darlington becomes saturated whereas the other remains open. The upper half of the bridge operates in the linear mode.

In stop condition both upper bridge darlings are off and both lower are on. In the high output impedance state the bridge is switched completely off.

Connecting the motor between pins 9 and 12 both left or right rotation can be obtained. If only one rotation sense is used the motor can be connected at only one output, by using only the upper bridge half. Two motors can be connected each at the each output : in such case they will work alternatively (see application section).

The internal diodes, together with the collector

substrate diodes, protect the output from inductive vol-tage spikes during the transition phase (fig. 10)

Figure 10.

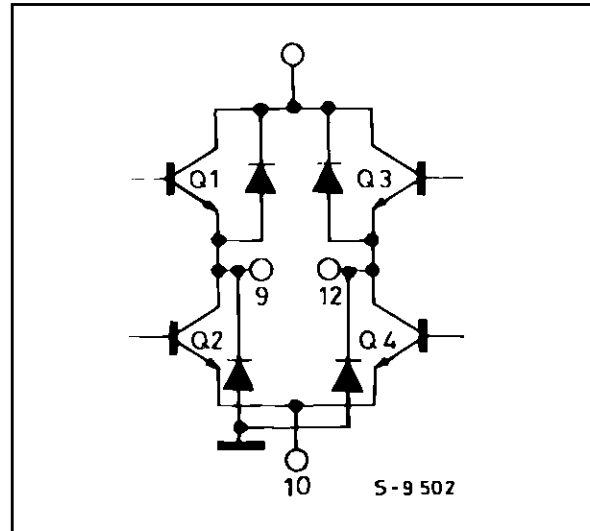

Pin 10

Common sense output. From this pin the output current of the bridge configuration (motor current) is fed into Rs external resistor in order to generate a proper voltage drop.

The drop is supplied into pin 1 for tachometric control and into pin 8 for V/I control (see pin 1 and pin 8 sections).

Pin 11

Supply voltage.

Pin 12

Output motor right. (see pin 9 section)

Pin 13

Output main amplifier. The voltage on this pin results from the tachometric speed control and feeds the output stage.

The value of the capacitor CF (fig. 11), connected from pins 13 and 14, must be chosen low enough in order to obtain a short reaction time of the tachometric loop, and high enough in order to reduce the output ripple.

A compromise is reached when the ripple voltage (peak-to-peak) VROP is equal to 0.1 VMOTOR :

$$C_F = 2.3 \frac{C_T}{V_{RIP}} \left(1 - \frac{R_T}{R_P} \right)$$

with $V_{RIP} = \frac{V_{FEM} + I_{MOT} \cdot R_{MOT}}{10}$ and with duty cycle = 50 %. (see pin 10 section)

Figure 11.

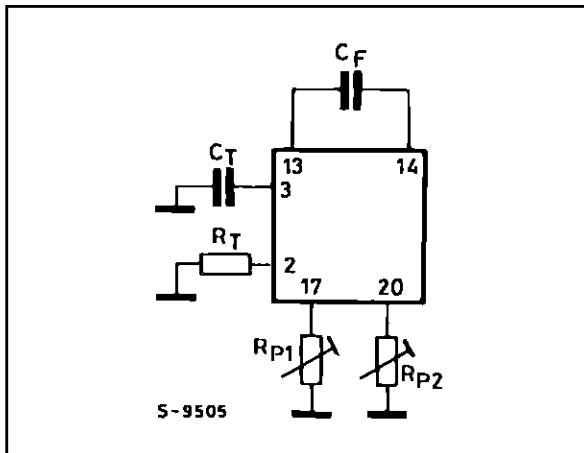
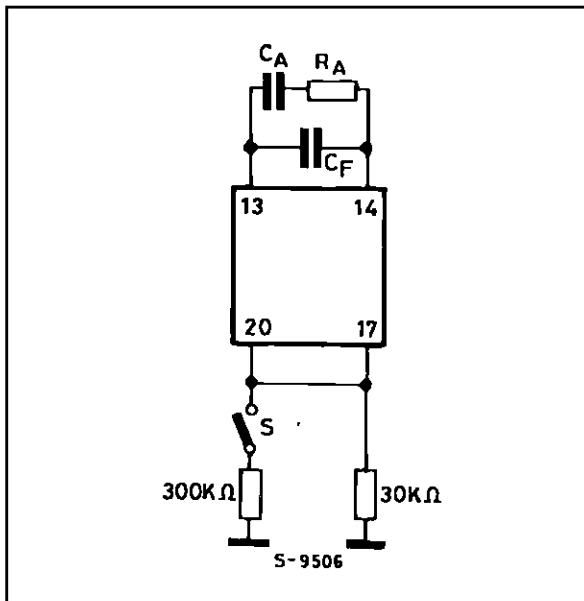

Figure 12.



In order to compensate the behaviour of the whole system regulator-motor-load (considering axis friction, load torque, inertias moment of the motor of the load, etc.) a RC series network is also connected between pins 13 and 14 (fig. 12). The value of C_A and R_A must be chosen experimentally as follows:

- Increase of 10 % the speed with respect to the nominal value by connecting in parallel to R_p a resistor with value about 10 time larger.
- Vary the R_A and C_A values in order to obtain at pin 13 a voltage signal with short response time and without oscillations. Fig. 13 shows the step response at pin 13 versus R_A and C_A values.

Pin 14

Figure 13.

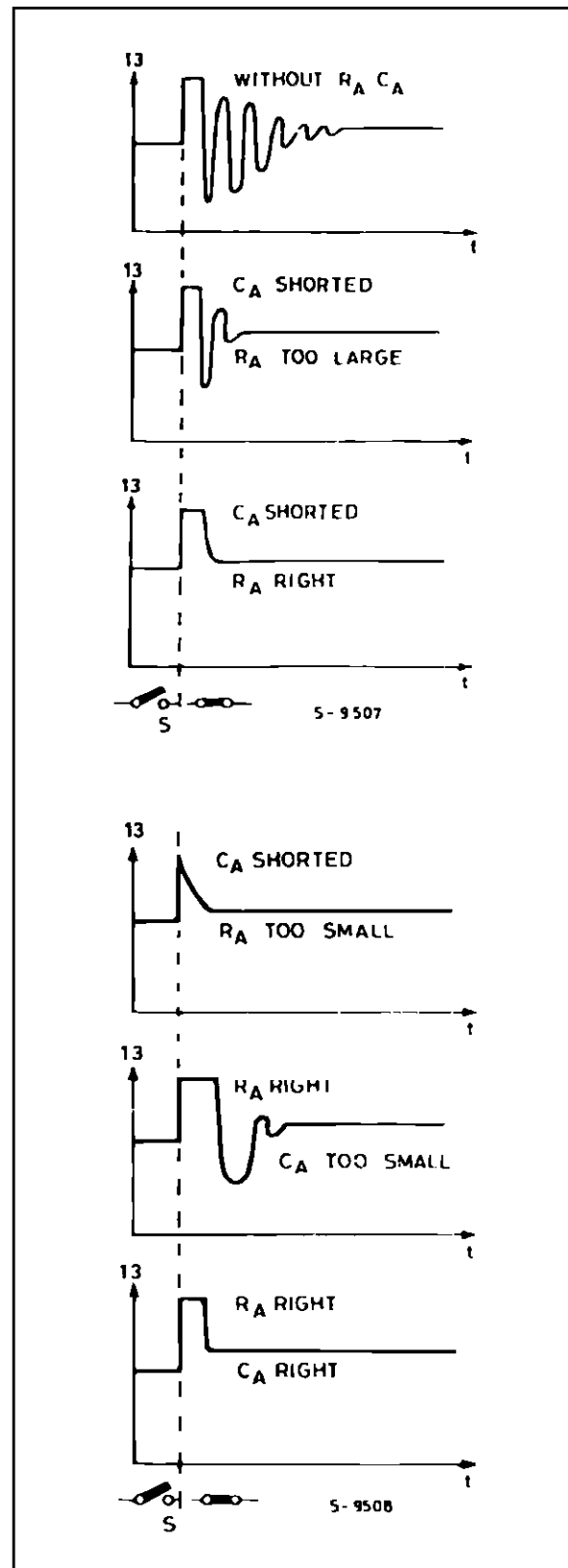
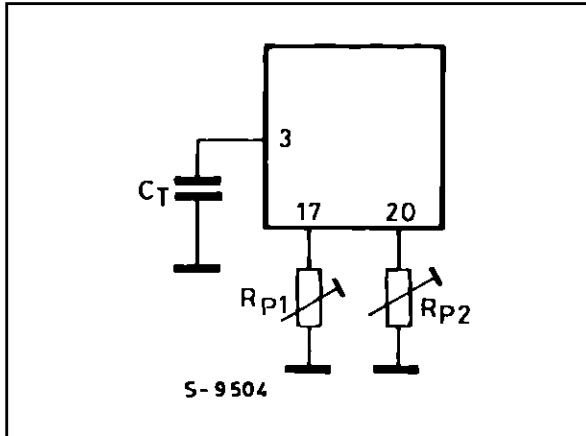

Figure 14.



Inverting input of main amplifier. In this pin the current reference programmed at pins 20, 17 is compared with the current from the monostable (stream of rectangular pulses).

In steady-state condition (constant motor speed) the values are equal and the capacitor C_F voltage is constant.

This means for the speed n (min -1):

$$n = \frac{10.435}{C_T k R_P}$$

where "k" is the number of collector segments (poles)

The non inverting input of the main amplifier is internally connected to a reference voltage (2.3 V).

Pin 15

Ground.

Pin 16

Ground.

Pin 17

Left speed adjustment. The voltage at this pin is fixed to a reference value of 0.8 V. A resistor from this pin and ground (fig. 14) fixes the reference current which will be compared with the medium output current of the monostable in order to fix the speed of the motor at the programmed value. The correct value of R_P would be :

$$R_P = \frac{10.435}{C_T k n}$$

n = motor speed, (min -1)

k = poles number

The control of speed can be done in different way:

- speed separately programmed in two senses of rotation (fig. 14-15) ;
- only one speed for the two senses of rotation (fig. 16) ;

Figure 15.

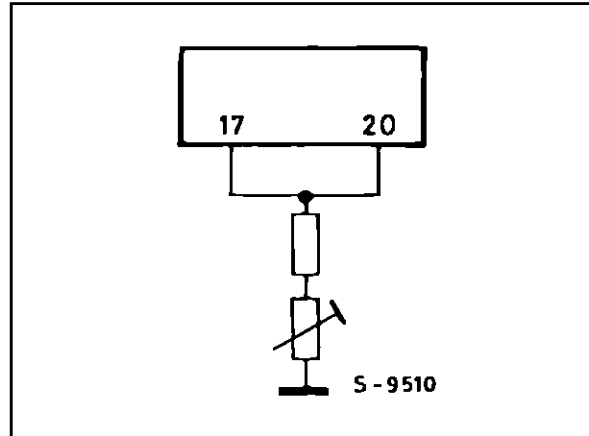

Figure 16.

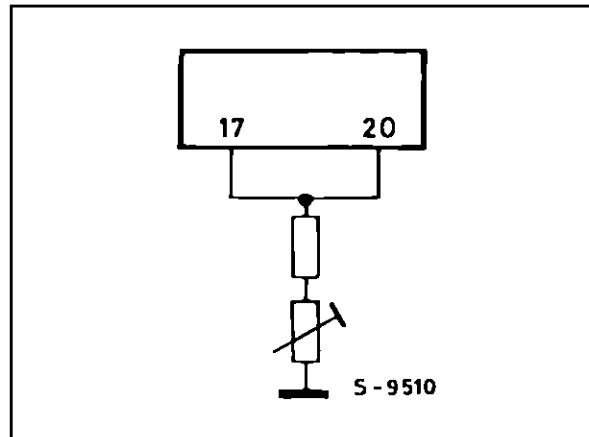
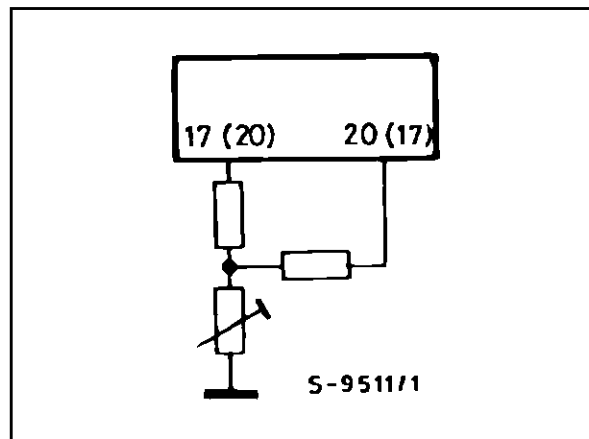

Figure 17.



- speeds of the two senses a bit different (i.e. for compensating different pulley effects) (fig. 17) ;
- speed programmed with a DC voltage (fig. 18) i.e. with DA converter ;

- fast forward, by putting a resistor. In this case it is necessary that also at the higher speed for the duty cycle to be significantly less than 1 (see value of R_T , C_T on pin 2, pin 3 sections).

Fig. 19 shows the function controlled with a μP .

Figure 18.

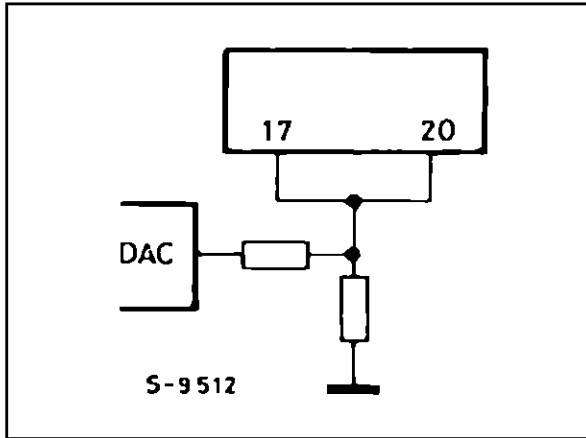

Pin 18

Right function control. The voltages applied to this pin and to pin 19 determine the function, as showed in the table.

Figure 19.

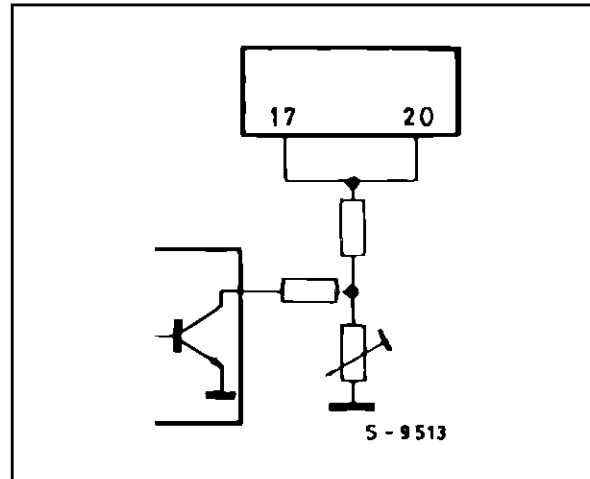

The typical value of the threshold (L-H) is 1.2 V.

Pin 19

Left function control. (see pin 18 sect).

Pin 20

Right speed adjustment. (see pin 17 sect).

CONDITION		OUTPUT FUNCTION	OUTPUT VOLTAGE	
Pin 18	Pin 19		Pin 12	Pin 9
L	L	STOP	LOW	LOW
H	L	LEFT	LOW	REG
L	H	RIGHT	REG	LOW
H	H	OPEN	HIGH IMP.	HIGH IMP.

Figure 20: Typical application.

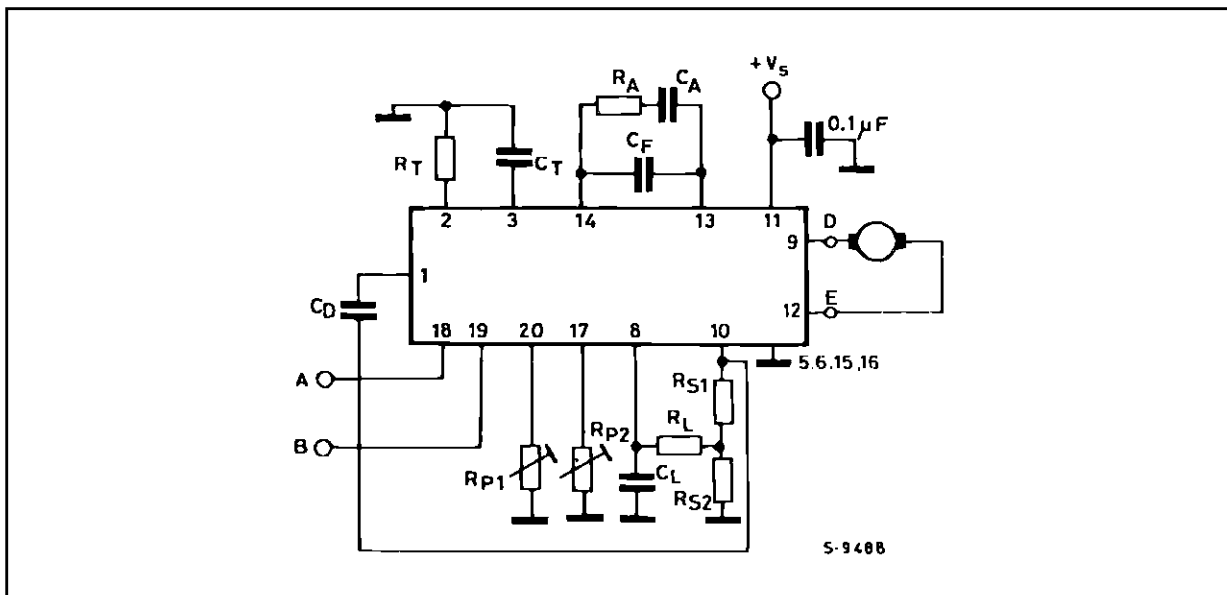

Figure 21: Tacho only speed regulation.

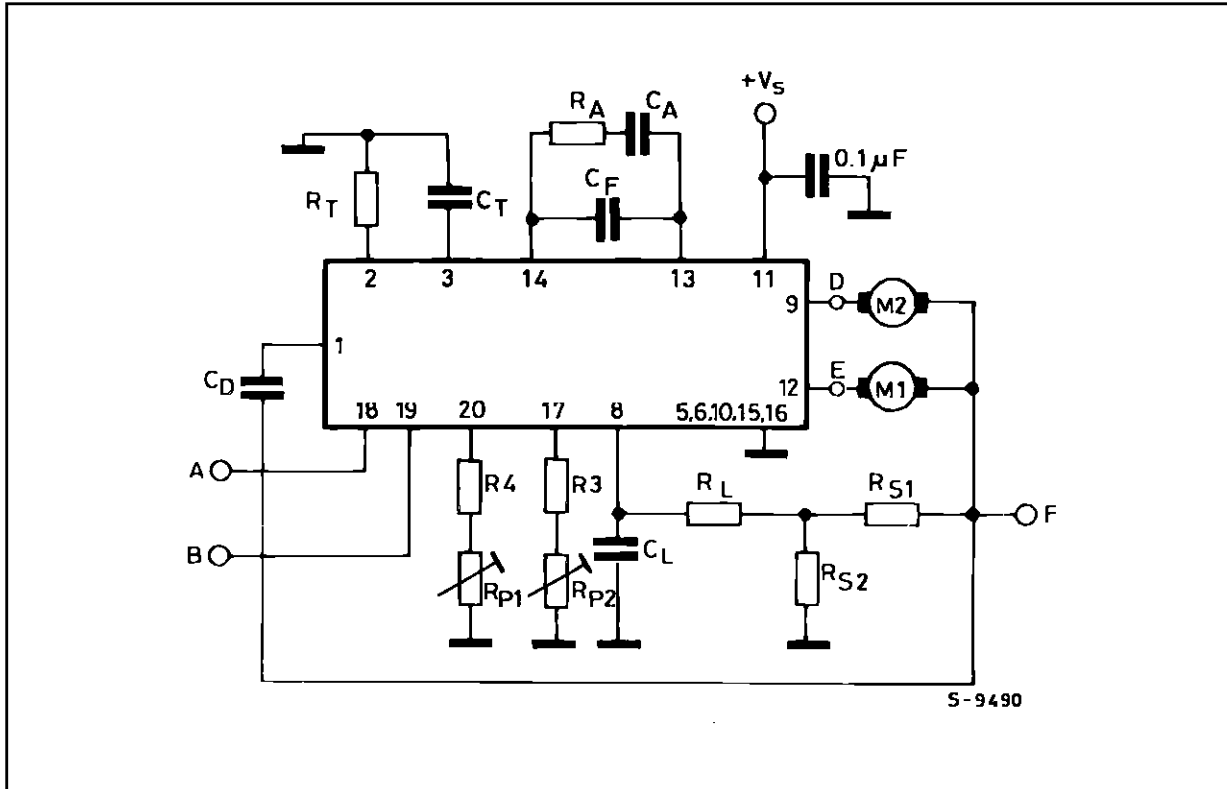

Figure 22: One direction regulator of one motor , or alternatively of two motors.

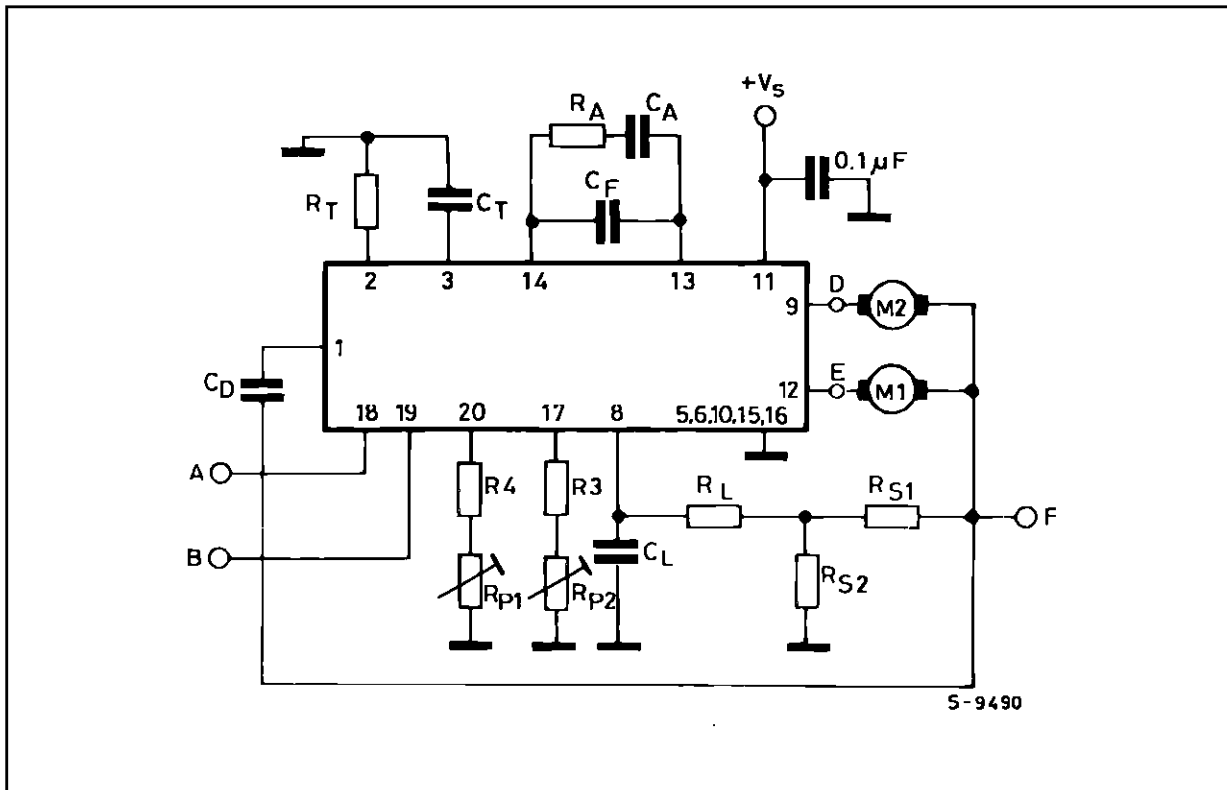
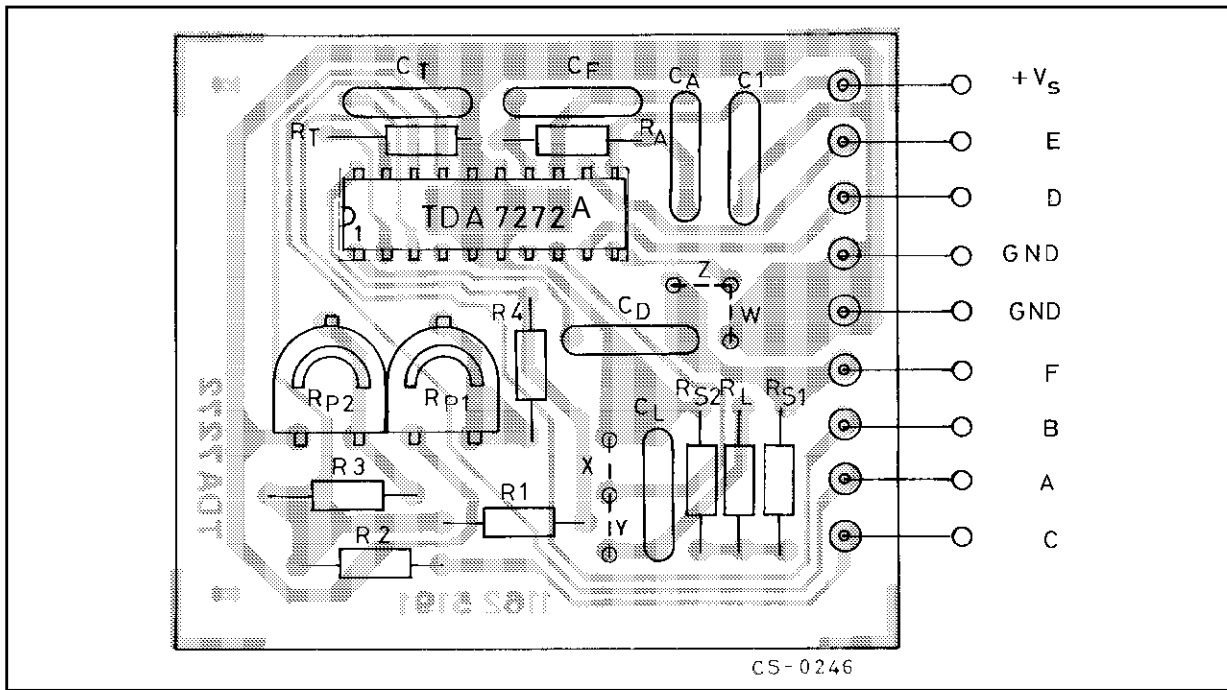

Figure 23: P.C. board and components layout of the circuits of Figg. 20, 21, 22.



APPLICATION SUGGESTION (Fig. 20,21,22) - (For a 2000 r.p.m. 3 pole DC motor with $R_M = 16\Omega$)

Components	Recommended value	Purpose	If larger	If smaller	Allowed range	
					Min.	Max.
R_{S1}	1Ω	Current sensing tacho loop.		Tacho loop do not regulate	0	
R_{S2}	1.5Ω	Current sensing V/I loop.	Instability may occur.	Motor regulator; undercompens.	0	$R_{MOT}/9$
$R_L; C_L$	$22K\Omega - 68nF$	Spike filtering.	Slow V/I regulator response.	High output ripple.		
C_D	$68nF$	Pulse transf.			$33nF$	$100nF$
$R_T; C_T$	$15K\Omega - 47nF$	Current source programming to obtain a 50% duty cycle			$67K\Omega$	$30KW$
$R_{P1}; R_{P2}$	$47K\Omega$ trim.	Set of speed.	Low speed.	High speed	0	
C_F	Polyester $100nF$	Optimization of integrator ripple and loop response time.	Lower ripple, slower tacho regulator response.	Higher ripple, faster response.	$10nF$	$470nF$
$R_A; C_A$	$220K\Omega - 220nF$	Fast response with no overshoot.	Depending on electromechanical system.		$10nF$	$470nF$

Figure 24: Speed regulation vs. supply voltage (circuit of fig. 20).

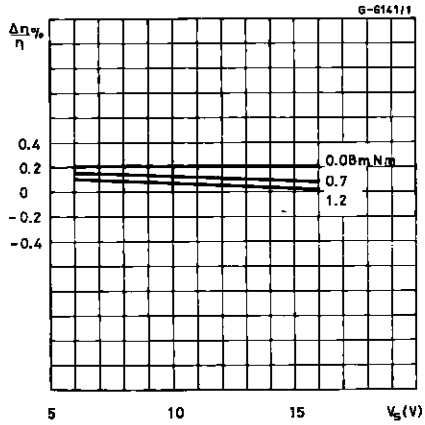
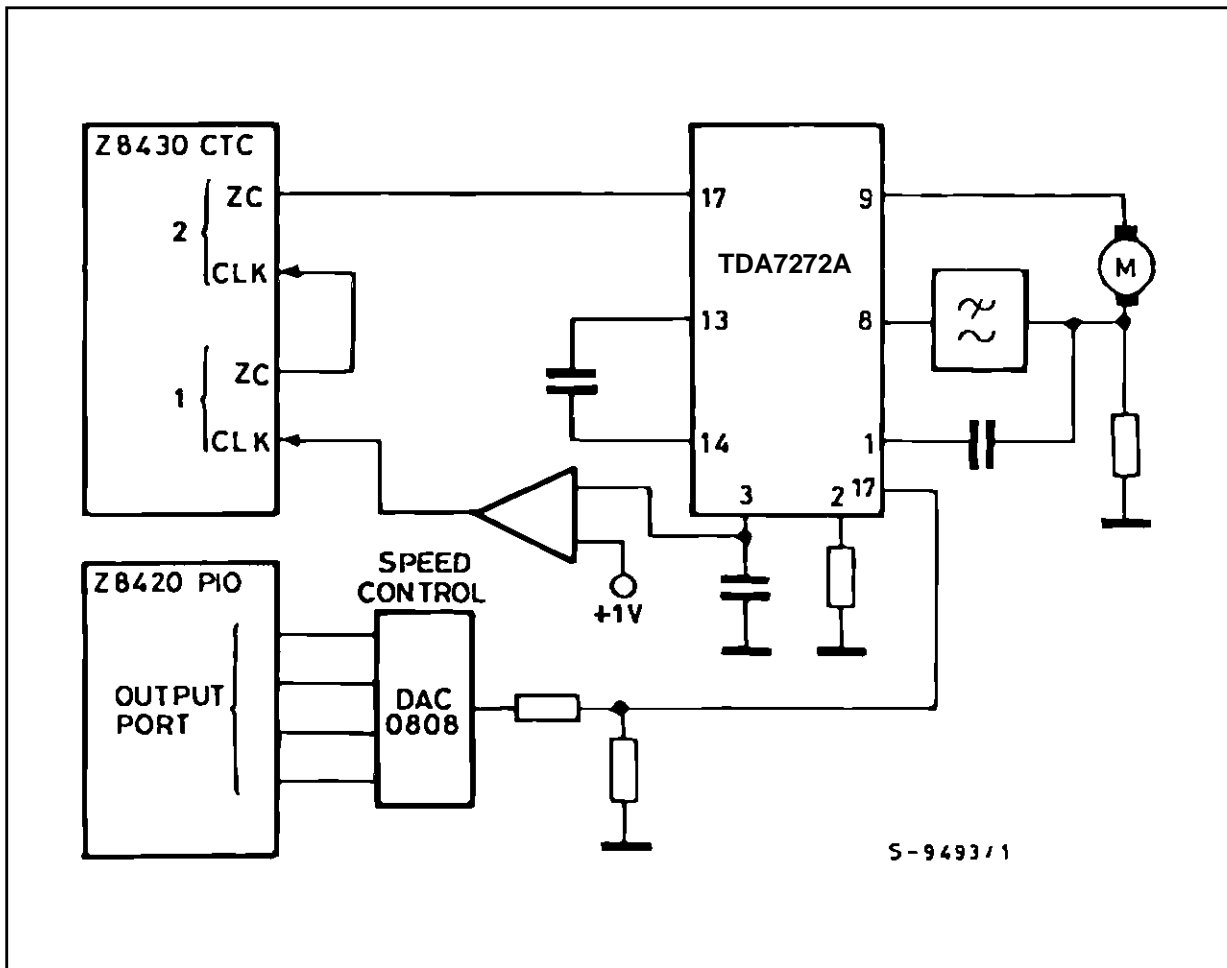
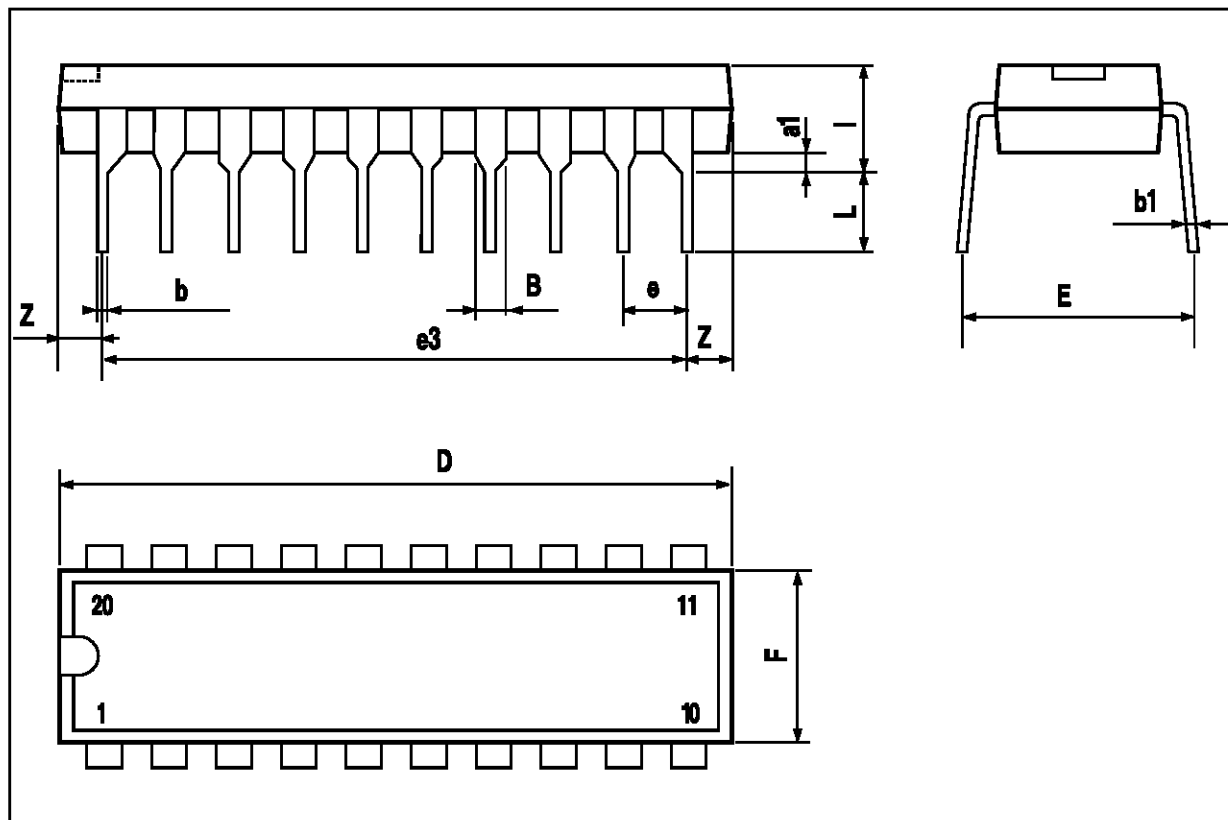

Figure 26: In connection with a Presettable Counter and I/O peripheral the TDA7271A/TDA7272A controls the speed through a D/A Converter.



POWERDIP 20 PACKAGE MECHANICAL DATA

DIM.	mm			inch		
	MIN.	TYP.	MAX.	MIN.	TYP.	MAX.
a1	0.51			0.020		
B	0.85		1.40	0.033		0.055
b		0.50			0.020	
b1	0.38		0.50	0.015		0.020
D			24.80			0.976
E		8.80			0.346	
e		2.54			0.100	
e3		22.86			0.900	
F			7.10			0.280
l			5.10			0.201
L		3.30			0.130	
Z			1.27			0.050



Information furnished is believed to be accurate and reliable. However, SGS-THOMSON Microelectronics assumes no responsibility for the consequences of use of such information nor for any infringement of patents or other rights of third parties which may result from its use. No license is granted by implication or otherwise under any patent or patent rights of SGS-THOMSON Microelectronics. Specifications mentioned in this publication are subject to change without notice. This publication supersedes and replaces all information previously supplied. SGS-THOMSON Microelectronics products are not authorized for use as critical components in life support devices or systems without express written approval of SGS-THOMSON Microelectronics.

© 1994 SGS-THOMSON Microelectronics - All Rights Reserved

SGS-THOMSON Microelectronics GROUP OF COMPANIES

Australia - Brazil - France - Germany - Hong Kong - Italy - Japan - Korea - Malaysia - Malta - Morocco - The Netherlands - Singapore - Spain - Sweden - Switzerland - Taiwan - Thailand - United Kingdom - U.S.A.